



US007926975B2

(12) **United States Patent**  
**Siemiet et al.**

(10) **Patent No.:** **US 7,926,975 B2**  
(45) **Date of Patent:** **Apr. 19, 2011**

(54) **LIGHT DISTRIBUTION USING A LIGHT  
EMITTING DIODE ASSEMBLY**

(75) Inventors: **Dennis Siemiet**, Rochester Hills, MI  
(US); **John Ivey**, Farmington Hills, MI  
(US); **Francis Palazzolo**, Sterling  
Heights, MI (US)

(73) Assignee: **Altair Engineering, Inc.**, Troy, MI (US)

(\*) Notice: Subject to any disclaimer, the term of this  
patent is extended or adjusted under 35  
U.S.C. 154(b) by 0 days.

80,419 A	1/1930	Kramer
84,763 A	7/1931	Stange
D119,797 S	4/1940	Winkler et al.
D125,312 S	2/1941	Logan
2,909,097 A	10/1959	Aiden et al.
3,318,185 A	5/1967	Kott
3,561,719 A	2/1971	Grindle
3,586,936 A	6/1971	McLeroy
3,601,621 A	8/1971	Ritchie
3,612,855 A	10/1971	Juhnke
3,643,088 A	2/1972	Osteen et al.
3,746,918 A	7/1973	Drucker et al.

(Continued)

**FOREIGN PATENT DOCUMENTS**

CN 1584388 2/2005

(Continued)

(21) Appl. No.: **12/724,645**

(22) Filed: **Mar. 16, 2010**

(65) **Prior Publication Data**

US 2010/0172149 A1 Jul. 8, 2010

**Related U.S. Application Data**

(63) Continuation of application No. 11/962,995, filed on  
Dec. 21, 2007, now Pat. No. 7,712,918.

(51) **Int. Cl.**

**F21V 1/00** (2006.01)

**F21V 7/04** (2006.01)

(52) **U.S. Cl.** ..... **362/240**; 362/246; 362/555

(58) **Field of Classification Search** ..... 362/240,  
362/241, 242, 246, 247, 249.02, 260, 311.02,  
362/555

See application file for complete search history.

(56) **References Cited**

**U.S. PATENT DOCUMENTS**

54,511 A	2/1920	Owen
58,105 A	6/1921	Poritz
79,814 A	8/1929	Hoch

**OTHER PUBLICATIONS**

Wolsey, Robert. Interoperable Systems: The Future of Lighting Control, Lighting Research Center, Jan. 1, 1997, vol. 2 No. 2, Rensselaer Polytechnic Institute, Troy, New York [online]. Retrieved Lighting Research Center Web Page using Internet <URL: <http://www.lrc.rpi.edu/programs/Futures/LF-BAS/index.asp>>.

(Continued)

*Primary Examiner* — Y My Quach Lee

(74) *Attorney, Agent, or Firm* — Young Basile

(57) **ABSTRACT**

A fluorescent light tube retrofit with light emitting diodes (LEDs) that evenly distribute light to avoid bright spots is disclosed. One LED lighting unit includes a tubular housing and a plurality of LED assemblies mounted about a circumference of the tubular housing. LEDs face inward from a mounting surface that is angled offset of the tube. Alternatively, at least one LED can be oriented to emit light parallel to a tangent of the housing into a light pipe that curves inside at least a portion of the tubular housing.

**19 Claims, 3 Drawing Sheets**

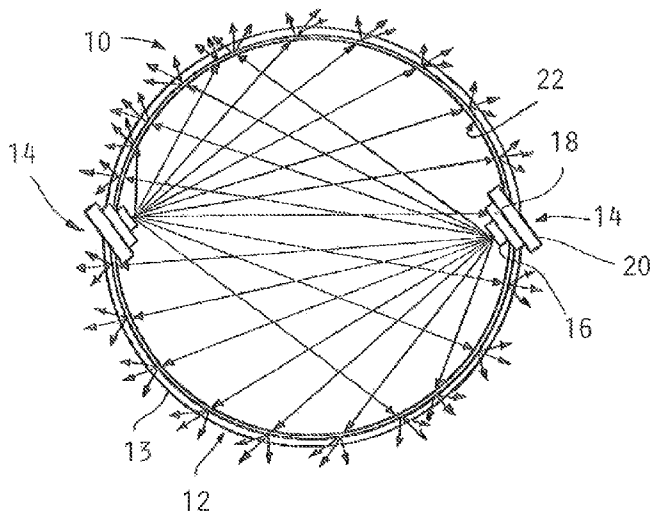

U.S. PATENT DOCUMENTS		
3,818,216 A	6/1974	Larraburu
3,832,503 A	8/1974	Crane
3,858,086 A	12/1974	Anderson et al.
3,909,670 A	9/1975	Wakamatsu et al.
3,924,120 A	12/1975	Cox, III
3,958,885 A	5/1976	Stockinger et al.
3,974,637 A	8/1976	Bergey et al.
3,993,386 A	11/1976	Rowe
4,001,571 A	1/1977	Martin
4,054,814 A	10/1977	Fegley et al.
4,070,568 A	1/1978	Gala
4,082,395 A	4/1978	Donato et al.
4,096,349 A	6/1978	Donato
4,102,558 A	7/1978	Krachman
4,107,581 A	8/1978	Abernethy
4,189,663 A	2/1980	Schmutzer et al.
4,211,955 A	7/1980	Ray
4,241,295 A	12/1980	Williams, Jr.
4,271,408 A	6/1981	Teshima et al.
4,272,689 A	6/1981	Crosby et al.
4,273,999 A	6/1981	Pierpoint
4,298,869 A	11/1981	Okuno
4,329,625 A	5/1982	Nishizawa et al.
4,339,788 A	7/1982	White et al.
4,342,947 A	8/1982	Bloyd
4,367,464 A	1/1983	Kurahashi et al.
D268,134 S	3/1983	Zurcher
4,382,272 A	5/1983	Quella et al.
4,388,567 A	6/1983	Yamazaki et al.
4,388,589 A	6/1983	Molldrem, Jr.
4,392,187 A	7/1983	Bornhorst
4,394,719 A	7/1983	Moberg
4,420,711 A	12/1983	Takahashi et al.
4,455,562 A	6/1984	Dolan et al.
4,500,796 A	2/1985	Quin
4,581,687 A	4/1986	Nakanishi
4,597,033 A	6/1986	Meggs et al.
4,600,972 A	7/1986	MacIntyre
4,607,317 A	8/1986	Lin
4,622,881 A	11/1986	Rand
4,625,152 A	11/1986	Nakai
4,635,052 A	1/1987	Aoike et al.
4,647,217 A	3/1987	Havel
4,656,398 A	4/1987	Michael et al.
4,661,890 A	4/1987	Watanabe et al.
4,668,895 A	5/1987	Schneiter
4,675,575 A	6/1987	Smith et al.
4,682,079 A	7/1987	Sanders et al.
4,686,425 A	8/1987	Havel
4,687,340 A	8/1987	Havel
4,688,154 A	8/1987	Nilssen
4,688,869 A	8/1987	Kelly
4,695,769 A	9/1987	Schweickardt
4,698,730 A	10/1987	Sakai et al.
4,701,669 A	10/1987	Head et al.
4,705,406 A	11/1987	Havel
4,707,141 A	11/1987	Havel
D293,723 S	1/1988	Buttner
4,727,289 A	2/1988	Uchida
4,740,882 A	4/1988	Miller
4,748,545 A	5/1988	Schmitt
4,753,148 A	6/1988	Johnson
4,758,173 A	7/1988	Northrop
4,771,274 A	9/1988	Havel
4,780,621 A	10/1988	Bartleucci et al.
4,794,383 A	12/1988	Havel
4,818,072 A	4/1989	Mohebban
4,824,269 A	4/1989	Havel
4,837,565 A	6/1989	White
4,843,627 A	6/1989	Stebbins
4,845,481 A	7/1989	Havel
4,845,745 A	7/1989	Havel
4,857,801 A	8/1989	Farrell
4,863,223 A	9/1989	Weissenbach et al.
4,870,325 A	9/1989	Kazar
4,874,320 A	10/1989	Freed et al.
4,887,074 A	12/1989	Simon et al.
4,894,832 A	1/1990	Colak
4,901,207 A	2/1990	Sato et al.
4,912,371 A	3/1990	Hamilton
4,922,154 A	5/1990	Cacoub
4,934,852 A	6/1990	Havel
4,941,072 A	7/1990	Yasumoto et al.
4,943,900 A	7/1990	Gartner
4,962,687 A	10/1990	Belliveau et al.
4,965,561 A	10/1990	Havel
4,973,835 A	11/1990	Kurosu et al.
4,979,081 A	12/1990	Leach et al.
4,980,806 A	12/1990	Taylor et al.
4,992,704 A	2/1991	Stinson
5,003,227 A	3/1991	Nilssen
5,008,595 A	4/1991	Kazar
5,008,788 A	4/1991	Palinkas
5,010,459 A	4/1991	Taylor et al.
5,018,054 A	5/1991	Ohashi et al.
5,027,037 A	6/1991	Wei
5,027,262 A	6/1991	Freed
5,034,807 A	7/1991	Von Kohorn
5,036,248 A	7/1991	McEwan et al.
5,038,255 A	8/1991	Nishihashi et al.
5,065,226 A	11/1991	Kluitmans et al.
5,072,216 A	12/1991	Grange
5,078,039 A	1/1992	Tulk et al.
5,083,063 A	1/1992	Brooks
5,088,013 A	2/1992	Revis
5,089,748 A	2/1992	Ihms
5,103,382 A	4/1992	Kondo et al.
5,122,733 A	6/1992	Havel
5,126,634 A	6/1992	Johnson
5,128,595 A	7/1992	Hara
5,130,909 A	7/1992	Gross
5,134,387 A	7/1992	Smith et al.
5,140,220 A	8/1992	Hasegawa
5,142,199 A	8/1992	Elwell
5,151,679 A	9/1992	Dimmick
5,154,641 A	10/1992	McLaughlin
5,161,879 A	11/1992	McDermott
5,164,715 A	11/1992	Kashiwabara et al.
5,184,114 A	2/1993	Brown
5,194,854 A	3/1993	Havel
5,198,756 A	3/1993	Jenkins et al.
5,209,560 A	5/1993	Taylor et al.
5,220,250 A	6/1993	Szuba
5,225,765 A	7/1993	Callahan et al.
5,226,723 A	7/1993	Chen
5,254,910 A	10/1993	Yang
5,256,948 A	10/1993	Boldin et al.
5,278,542 A	1/1994	Smith et al.
5,282,121 A	1/1994	Bornhorst et al.
5,283,517 A	2/1994	Havel
5,287,352 A	2/1994	Jackson et al.
5,294,865 A	3/1994	Haraden
5,298,871 A	3/1994	Shimohara
5,301,090 A	4/1994	Hed
5,303,124 A	4/1994	Wrobel
5,307,295 A	4/1994	Taylor et al.
5,321,593 A	6/1994	Moates
5,323,226 A	6/1994	Schreder
5,329,431 A	7/1994	Taylor et al.
5,344,068 A	9/1994	Haessig
5,350,977 A	9/1994	Hamamoto et al.
5,357,170 A	10/1994	Luchaco et al.
5,371,618 A	12/1994	Tai et al.
5,374,876 A	12/1994	Horibata et al.
5,375,043 A	12/1994	Tokunaga
D354,360 S	1/1995	Murata
5,381,074 A	1/1995	Rudzewicz et al.
5,388,357 A	2/1995	Malita
5,402,702 A	4/1995	Hata
5,404,282 A	4/1995	Klinke et al.
5,406,176 A	4/1995	Sugden
5,410,328 A	4/1995	Yoksza et al.
5,412,284 A	5/1995	Moore et al.
5,412,552 A	5/1995	Fernandes
5,420,482 A	5/1995	Phares
5,421,059 A	6/1995	Leffers, Jr.
5,430,356 A	7/1995	Ference et al.

5,432,408 A	7/1995	Matsuda et al.	5,907,742 A	5/1999	Johnson et al.
5,436,535 A	7/1995	Yang	5,912,653 A	6/1999	Fitch
5,436,853 A	7/1995	Shimohara	5,921,660 A	7/1999	Yu
5,450,301 A	9/1995	Waltz et al.	5,924,784 A	7/1999	Chliwnyj et al.
5,461,188 A	10/1995	Drago et al.	5,927,845 A	7/1999	Gustafson et al.
5,463,280 A	10/1995	Johnson	5,946,209 A	8/1999	Eckel et al.
5,465,144 A	11/1995	Parker et al.	5,949,347 A	9/1999	Wu
5,475,300 A	12/1995	Havel	5,952,680 A	9/1999	Strite
5,489,827 A	2/1996	Xia	5,959,547 A	9/1999	Tubel et al.
5,491,402 A	2/1996	Small	5,962,989 A	10/1999	Baker
5,493,183 A	2/1996	Kimball	5,962,992 A	10/1999	Huang et al.
5,504,395 A	4/1996	Johnson et al.	5,963,185 A	10/1999	Havel
5,513,082 A	4/1996	Asano	5,974,553 A	10/1999	Gandar
5,519,496 A	5/1996	Borgert et al.	5,980,064 A	11/1999	Metroyanis
5,530,322 A	6/1996	Ference et al.	5,998,928 A	12/1999	Hipp
5,544,809 A	8/1996	Keating et al.	6,007,209 A	12/1999	Peika
5,545,950 A	8/1996	Cho	6,008,783 A	12/1999	Kitagawa et al.
5,550,440 A	8/1996	Allison et al.	6,011,691 A	1/2000	Schreffler
5,559,681 A	9/1996	Duarte	6,016,038 A	1/2000	Mueller et al.
5,561,346 A	10/1996	Byrne	6,018,237 A	1/2000	Havel
D376,030 S	11/1996	Cohen	6,020,825 A	2/2000	Chansky et al.
5,575,459 A	11/1996	Anderson	6,025,550 A	2/2000	Kato
5,575,554 A	11/1996	Guritz	6,028,694 A	2/2000	Schmidt
5,581,158 A	12/1996	Quazi	6,030,099 A	2/2000	McDermott
5,592,051 A	1/1997	Korkala	6,031,343 A	2/2000	Recknagel et al.
5,607,227 A	3/1997	Yasumoto et al.	D422,737 S	4/2000	Orozco
5,608,290 A	3/1997	Hutchisson et al.	6,068,383 A	5/2000	Robertson et al.
5,614,788 A	3/1997	Mullins et al.	6,069,597 A	5/2000	Hansen
5,621,282 A	4/1997	Haskell	6,072,280 A	6/2000	Allen
5,621,603 A	4/1997	Adamec et al.	6,084,359 A	7/2000	Hetzl et al.
5,621,662 A	4/1997	Humphries et al.	6,091,200 A	7/2000	Lenz
5,622,423 A	4/1997	Lee	6,092,915 A	7/2000	Rensch
5,633,629 A	5/1997	Hochstein	6,095,661 A	8/2000	Lebens et al.
5,634,711 A	6/1997	Kennedy et al.	6,097,352 A	8/2000	Zavracky et al.
5,640,061 A	6/1997	Bornhorst et al.	6,121,875 A	9/2000	Hamm et al.
5,640,141 A	6/1997	Myllymaki	6,127,783 A	10/2000	Pashley et al.
5,642,129 A	6/1997	Zavracky et al.	6,132,072 A	10/2000	Turnbull et al.
5,655,830 A	8/1997	Ruskouski	6,135,604 A	10/2000	Lin
5,656,935 A	8/1997	Havel	6,139,174 A	10/2000	Butterworth
5,661,645 A	8/1997	Hochstein	6,149,283 A	11/2000	Conway et al.
5,673,059 A	9/1997	Zavracky et al.	6,150,774 A	11/2000	Mueller et al.
5,682,103 A	10/1997	Burrell	6,151,529 A	11/2000	Bafko
5,688,042 A	11/1997	Madadi et al.	6,158,882 A	12/2000	Bischoff, Jr.
5,697,695 A	12/1997	Lin et al.	6,166,496 A	12/2000	Lys et al.
5,701,058 A	12/1997	Roth	6,175,201 B1	1/2001	Sid
5,712,650 A	1/1998	Barlow	6,175,220 B1	1/2001	Billig et al.
5,721,471 A	2/1998	Begemann et al.	6,181,126 B1	1/2001	Havel
5,725,148 A	3/1998	Hartman	6,183,086 B1	2/2001	Neubert
5,726,535 A	3/1998	Yan	6,183,104 B1	2/2001	Ferrara
5,731,759 A	3/1998	Finucan	6,184,628 B1	2/2001	Ruthenberg
5,734,590 A	3/1998	Tebbe	6,196,471 B1	3/2001	Ruthenberg
5,751,118 A	5/1998	Mortimer	6,211,626 B1	4/2001	Lys et al.
5,752,766 A	5/1998	Bailey et al.	6,215,409 B1	4/2001	Blach
5,765,940 A	6/1998	Levy et al.	6,217,190 B1	4/2001	Altman et al.
5,769,527 A	6/1998	Taylor et al.	6,219,239 B1	4/2001	Mellberg et al.
5,784,006 A	7/1998	Hochstein	6,227,679 B1	5/2001	Zhang et al.
5,790,329 A	8/1998	Klaus et al.	6,241,359 B1	6/2001	Lin
5,803,579 A	9/1998	Turnbull et al.	6,250,774 B1	6/2001	Begemann et al.
5,803,580 A	9/1998	Tseng	6,252,350 B1	6/2001	Alvarez
5,803,729 A	9/1998	Tsimerman	6,252,358 B1	6/2001	Xydis et al.
5,808,689 A	9/1998	Small	6,268,600 B1	7/2001	Nakamura et al.
5,810,463 A	9/1998	Kawahara et al.	6,273,338 B1	8/2001	White
5,812,105 A	9/1998	Van de Ven	6,275,397 B1	8/2001	McClain
5,813,751 A	9/1998	Shaffer	6,283,612 B1	9/2001	Hunter
5,813,753 A	9/1998	Vriens et al.	6,292,901 B1	9/2001	Lys et al.
5,821,695 A	10/1998	Vilanilam et al.	6,293,684 B1	9/2001	Riblett
5,825,051 A	10/1998	Bauer et al.	6,297,724 B1	10/2001	Bryans et al.
5,828,178 A	10/1998	York et al.	6,305,109 B1	10/2001	Lee
5,836,676 A	11/1998	Ando et al.	6,305,821 B1	10/2001	Hsieh et al.
5,848,837 A	12/1998	Gustafson	6,307,331 B1	10/2001	Bonasia et al.
5,850,126 A	12/1998	Kanbar	6,310,590 B1	10/2001	Havel
5,851,063 A	12/1998	Doughty et al.	6,323,832 B1	11/2001	Nishizawa et al.
5,852,658 A	12/1998	Knight et al.	6,325,651 B1	12/2001	Nishihara et al.
5,854,542 A	12/1998	Forbes	6,334,699 B1	1/2002	Gladnick
RE36,030 E	1/1999	Nadeau	6,340,868 B1	1/2002	Lys et al.
5,859,508 A	1/1999	Ge et al.	6,354,714 B1	3/2002	Rhodes
5,865,529 A	2/1999	Yan	6,361,186 B1	3/2002	Slayden
5,890,794 A	4/1999	Abtahi et al.	6,369,525 B1	4/2002	Chang et al.
5,896,010 A	4/1999	Mikolajczak et al.	6,371,637 B1	4/2002	Atchinson et al.

6,373,733	B1	4/2002	Wu et al.	6,774,584	B2	8/2004	Lys et al.
6,379,022	B1	4/2002	Amerson et al.	6,777,891	B2	8/2004	Lys et al.
D457,667	S	5/2002	Piepgras et al.	6,781,329	B2	8/2004	Mueller et al.
D457,669	S	5/2002	Piepgras et al.	6,787,999	B2	9/2004	Stimac et al.
D457,974	S	5/2002	Piepgras et al.	6,788,000	B2	9/2004	Appelberg et al.
6,394,623	B1	5/2002	Tsui	6,788,011	B2	9/2004	Mueller et al.
D458,395	S	6/2002	Piepgras et al.	6,791,840	B2	9/2004	Chun
6,400,096	B1	6/2002	Wells et al.	6,801,003	B2	10/2004	Schanberger et al.
6,404,131	B1	6/2002	Kawano et al.	6,806,659	B1	10/2004	Mueller et al.
6,411,022	B1	6/2002	Machida	6,814,470	B2	11/2004	Rizkin et al.
6,422,716	B2	7/2002	Henrici et al.	6,815,724	B2	11/2004	Dry
6,428,189	B1	8/2002	Hochstein	6,846,094	B2	1/2005	Luk
D463,610	S	9/2002	Piepgras et al.	6,851,816	B2	2/2005	Wu et al.
6,445,139	B1	9/2002	Marshall et al.	6,851,832	B2	2/2005	Tieszen
6,448,550	B1	9/2002	Nishimura	6,853,151	B2	2/2005	Leong et al.
6,448,716	B1	9/2002	Hutchison	6,853,563	B1	2/2005	Yang et al.
6,459,919	B1	10/2002	Lys et al.	6,857,924	B2	2/2005	Fu et al.
6,469,457	B2	10/2002	Callahan	6,860,628	B2	3/2005	Robertson et al.
6,471,388	B1	10/2002	Marsh	6,866,401	B2	3/2005	Sommers et al.
6,472,823	B2	10/2002	Yen	6,869,204	B2	3/2005	Morgan et al.
6,473,002	B1	10/2002	Hutchison	6,871,981	B2	3/2005	Alexanderson et al.
D468,035	S	12/2002	Blanc et al.	6,874,924	B1	4/2005	Hulse et al.
6,488,392	B1	12/2002	Lu	6,879,883	B1	4/2005	Motoyama
6,495,964	B1	12/2002	Muthu et al.	6,882,111	B2	4/2005	Kan et al.
6,527,411	B1	3/2003	Sayers	6,883,929	B2	4/2005	Dowling
6,528,954	B1	3/2003	Lys et al.	6,883,934	B2	4/2005	Kawakami et al.
6,528,958	B2	3/2003	Hulshof et al.	6,888,322	B2	5/2005	Dowling et al.
6,538,375	B1	3/2003	Duggal et al.	6,897,624	B2	5/2005	Lys et al.
6,548,967	B1	4/2003	Dowling et al.	6,909,239	B2	6/2005	Gauna
6,573,536	B1	6/2003	Dry	6,909,921	B1	6/2005	Bilger
6,577,072	B2	6/2003	Saito et al.	6,918,680	B2	7/2005	Seeberger
6,577,080	B2	6/2003	Lys et al.	6,921,181	B2	7/2005	Yen
6,577,512	B2	6/2003	Tripathi et al.	6,936,968	B2	8/2005	Cross et al.
6,577,794	B1	6/2003	Currie et al.	6,936,978	B2	8/2005	Morgan et al.
6,578,979	B2	6/2003	Truttmann-Böttig	6,940,230	B2	9/2005	Myron et al.
6,582,103	B1	6/2003	Popovich et al.	6,948,829	B2	9/2005	Verdes et al.
6,583,550	B2	6/2003	Iwasa et al.	6,964,501	B2	11/2005	Ryan
6,583,573	B2	6/2003	Bierman	6,965,197	B2	11/2005	Tyan et al.
6,586,890	B2	7/2003	Min et al.	6,965,205	B2	11/2005	Piepgras et al.
6,592,238	B2	7/2003	Cleaver et al.	6,967,448	B2	11/2005	Morgan et al.
6,596,977	B2	7/2003	Muthu et al.	6,969,179	B2	11/2005	Sloan et al.
6,598,996	B1	7/2003	Lodhie	6,969,186	B2	11/2005	Sonderegger et al.
6,608,453	B2	8/2003	Morgan et al.	6,969,954	B2	11/2005	Lys
6,608,614	B1	8/2003	Johnson	6,975,079	B2	12/2005	Lys et al.
6,609,804	B2	8/2003	Nolan et al.	6,979,097	B2	12/2005	Elam et al.
6,612,712	B2	9/2003	Nepil	6,982,518	B2	1/2006	Chou et al.
6,612,717	B2	9/2003	Yen	6,995,681	B2	2/2006	Pederson
6,612,729	B1 *	9/2003	Hoffman ..... 362/555	6,997,576	B1	2/2006	Lodhie et al.
6,621,222	B1	9/2003	Hong	7,004,603	B2	2/2006	Knight
6,623,151	B2	9/2003	Pederson	D518,218	S	3/2006	Roberge et al.
6,624,597	B2	9/2003	Dowling et al.	7,008,079	B2	3/2006	Smith
D481,484	S	10/2003	Cuevas et al.	7,014,336	B1	3/2006	Ducharme et al.
6,634,770	B2	10/2003	Cao	7,015,650	B2	3/2006	McGrath
6,634,779	B2	10/2003	Reed	7,018,063	B2	3/2006	Michael et al.
6,636,003	B2	10/2003	Rahm et al.	7,021,799	B2	4/2006	Mizuyoshi
6,639,349	B1	10/2003	Bahadur	7,021,809	B2	4/2006	Iwasa et al.
6,641,284	B2	11/2003	Stopa et al.	7,024,256	B2	4/2006	Krzyzanowski et al.
6,659,622	B2	12/2003	Katogi et al.	7,031,920	B2	4/2006	Dowling et al.
6,660,935	B2	12/2003	Southard et al.	7,033,036	B2	4/2006	Pederson
6,666,689	B1	12/2003	Savage, Jr.	7,038,398	B1	5/2006	Lys et al.
6,667,623	B2	12/2003	Bourgault et al.	7,038,399	B2	5/2006	Lys et al.
6,674,096	B2	1/2004	Sommers	7,042,172	B2	5/2006	Dowling et al.
6,676,284	B1	1/2004	Willson	7,048,423	B2	5/2006	Stepanenko et al.
6,679,621	B2	1/2004	West et al.	7,049,761	B2	5/2006	Timmermans et al.
6,681,154	B2	1/2004	Nierlich et al.	7,052,171	B1	5/2006	Lefebvre et al.
6,682,205	B2	1/2004	Lin	7,053,557	B2	5/2006	Cross et al.
6,683,419	B2	1/2004	Kriparos	7,064,498	B2	6/2006	Dowling et al.
6,700,136	B2	3/2004	Guida	7,064,674	B2	6/2006	Pederson
6,712,486	B1	3/2004	Popovich et al.	7,067,992	B2	6/2006	Leong et al.
6,717,376	B2	4/2004	Lys et al.	7,077,978	B2	7/2006	Setlur et al.
6,717,526	B2	4/2004	Martineau et al.	7,080,927	B2	7/2006	Feuerborn et al.
6,720,745	B2	4/2004	Lys et al.	7,086,747	B2	8/2006	Nielson et al.
6,726,348	B2	4/2004	Gloisten	7,088,014	B2	8/2006	Nierlich et al.
6,741,324	B1	5/2004	Kim	7,088,904	B2	8/2006	Ryan, Jr.
D491,678	S	6/2004	Piepgras	7,102,902	B1	9/2006	Brown et al.
D492,042	S	6/2004	Piepgras	7,113,541	B1	9/2006	Lys et al.
6,744,223	B2	6/2004	Laflamme et al.	7,114,830	B2	10/2006	Robertson et al.
6,748,299	B1	6/2004	Motoyama	7,114,834	B2	10/2006	Rivas et al.
6,762,562	B2	7/2004	Leong	7,118,262	B2	10/2006	Negley

7,119,503 B2	10/2006	Kemper	7,270,443 B2	9/2007	Kurtz et al.
7,121,679 B2	10/2006	Fujimoto	7,271,794 B1	9/2007	Cheng et al.
7,122,976 B1	10/2006	Null et al.	7,273,300 B2	9/2007	Mrakovich
7,128,442 B2	10/2006	Lee et al.	7,274,045 B2	9/2007	Chandran et al.
7,128,454 B2	10/2006	Kim et al.	7,274,160 B2	9/2007	Mueller et al.
D532,532 S	11/2006	Maxik	D553,267 S	10/2007	Yuen
7,132,635 B2	11/2006	Dowling	7,285,801 B2	10/2007	Eliashevich et al.
7,132,785 B2	11/2006	Ducharme	7,288,902 B1	10/2007	Melanson
7,132,804 B2	11/2006	Lys et al.	7,296,912 B2	11/2007	Beauchamp
7,135,824 B2	11/2006	Lys et al.	7,300,184 B2	11/2007	Ichikawa et al.
7,139,617 B1	11/2006	Morgan et al.	7,300,192 B2	11/2007	Mueller et al.
7,144,135 B2	12/2006	Martin et al.	D556,937 S	12/2007	Ly
7,153,002 B2	12/2006	Kim et al.	D557,854 S	12/2007	Lewis
7,161,311 B2	1/2007	Mueller et al.	7,303,300 B2	12/2007	Dowling et al.
7,161,313 B2	1/2007	Piegras et al.	7,306,353 B2	12/2007	Popovich et al.
7,161,556 B2	1/2007	Morgan et al.	7,307,391 B2	12/2007	Shan
7,164,110 B2	1/2007	Pitigoi-Aron et al.	7,308,296 B2	12/2007	Lys et al.
7,165,863 B1	1/2007	Thomas et al.	7,309,965 B2	12/2007	Dowling et al.
7,165,866 B2	1/2007	Li	7,318,658 B2	1/2008	Wang et al.
7,167,777 B2	1/2007	Budike, Jr.	7,319,244 B2	1/2008	Liu et al.
7,168,843 B2	1/2007	Striebel	7,319,246 B2	1/2008	Soules et al.
D536,468 S	2/2007	Crosby	7,321,191 B2	1/2008	Setlur et al.
7,178,941 B2	2/2007	Roberge et al.	7,326,964 B2	2/2008	Lim et al.
7,180,252 B2	2/2007	Lys et al.	7,329,031 B2	2/2008	Liaw et al.
D538,950 S	3/2007	Maxik	D563,589 S	3/2008	Hariri et al.
D538,952 S	3/2007	Maxik et al.	7,345,320 B2	3/2008	Dahm
D538,962 S	3/2007	Elliott	7,348,604 B2	3/2008	Matheson
7,186,003 B2	3/2007	Dowling et al.	7,350,936 B2	4/2008	Ducharme et al.
7,186,005 B2	3/2007	Hulse	7,350,952 B2	4/2008	Nishigaki
7,187,141 B2	3/2007	Mueller et al.	7,352,138 B2	4/2008	Lys et al.
7,190,126 B1	3/2007	Paton	7,352,339 B2	4/2008	Morgan et al.
7,192,154 B2	3/2007	Becker	7,353,071 B2	4/2008	Blackwell et al.
7,201,491 B2	4/2007	Bayat et al.	7,358,679 B2	4/2008	Lys et al.
7,201,497 B2	4/2007	Weaver, Jr. et al.	7,358,929 B2	4/2008	Mueller et al.
7,202,613 B2	4/2007	Morgan et al.	7,374,327 B2	5/2008	Schexnaider
7,204,615 B2	4/2007	Arik et al.	7,385,359 B2	6/2008	Dowling et al.
7,204,622 B2	4/2007	Dowling et al.	7,391,159 B2	6/2008	Harwood
7,207,696 B1	4/2007	Lin	7,396,146 B2	7/2008	Wang
7,210,818 B2	5/2007	Luk et al.	7,401,935 B2	7/2008	VanderSchuit
7,210,957 B2	5/2007	Mrakovich	7,401,945 B2	7/2008	Zhang
7,211,959 B1	5/2007	Chou	7,427,840 B2	9/2008	Morgan et al.
7,213,934 B2	5/2007	Zarian et al.	7,429,117 B2	9/2008	Pohlert et al.
7,217,012 B2	5/2007	Southard et al.	7,438,441 B2	10/2008	Sun et al.
7,217,022 B2	5/2007	Ruffin	7,449,847 B2	11/2008	Schanberger et al.
7,218,056 B1	5/2007	Harwood	7,476,004 B2	1/2009	Chan
7,218,238 B2	5/2007	Right et al.	7,478,924 B2	1/2009	Robertson
7,220,015 B2	5/2007	Dowling	7,490,957 B2	2/2009	Leong et al.
7,221,104 B2	5/2007	Lys et al.	7,497,596 B2	3/2009	Ge
7,221,110 B2	5/2007	Sears et al.	7,507,001 B2	3/2009	Kit
7,224,000 B2	5/2007	Aanegola et al.	7,510,299 B2	3/2009	Timmermans et al.
7,226,189 B2	6/2007	Lee et al.	7,521,872 B2	4/2009	Bruning
7,228,052 B1	6/2007	Lin	7,524,089 B2	4/2009	Park
7,228,190 B2	6/2007	Dowling et al.	7,534,002 B2	5/2009	Yamaguchi et al.
7,231,060 B2	6/2007	Dowling et al.	7,549,769 B2	6/2009	Kim et al.
7,233,115 B2	6/2007	Lys	7,556,396 B2	7/2009	Kuo et al.
7,233,831 B2	6/2007	Blackwell	7,572,030 B2	8/2009	Booth et al.
7,236,366 B2	6/2007	Chen	7,575,339 B2	8/2009	Hung
7,237,924 B2	7/2007	Martineau et al.	7,619,366 B2	11/2009	Diederiks
7,237,925 B2	7/2007	Mayer et al.	7,635,201 B2	12/2009	Deng
7,239,532 B1	7/2007	Hsu et al.	2001/0033488 A1	10/2001	Chliwnyj et al.
7,241,038 B2	7/2007	Naniwa et al.	2001/0045803 A1	11/2001	Cencur
7,242,152 B2	7/2007	Dowling et al.	2002/0038157 A1	3/2002	Dowling et al.
7,246,926 B2	7/2007	Harwood	2002/0044066 A1	4/2002	Dowling et al.
7,246,931 B2	7/2007	Hsieh et al.	2002/0047569 A1	4/2002	Dowling et al.
7,248,239 B2	7/2007	Dowling et al.	2002/0047624 A1	4/2002	Stam et al.
7,249,269 B1	7/2007	Motoyama	2002/0047628 A1	4/2002	Morgan et al.
7,249,865 B2	7/2007	Robertson	2002/0048169 A1	4/2002	Dowling et al.
D548,868 S	8/2007	Roberge et al.	2002/0057061 A1	5/2002	Mueller et al.
7,252,408 B2	8/2007	Mazzochette et al.	2002/0060526 A1	5/2002	Timmermans et al.
7,253,566 B2	8/2007	Lys et al.	2002/0070688 A1	6/2002	Dowling et al.
7,255,457 B2	8/2007	Ducharme et al.	2002/0074559 A1	6/2002	Dowling et al.
7,255,460 B2	8/2007	Lee	2002/0078221 A1	6/2002	Blackwell et al.
7,256,554 B2	8/2007	Lys	2002/0101197 A1	8/2002	Lys et al.
7,258,458 B2	8/2007	Mochiachvili et al.	2002/0113555 A1	8/2002	Lys et al.
7,258,467 B2	8/2007	Saccomanno et al.	2002/0130627 A1	9/2002	Morgan et al.
7,259,528 B2	8/2007	Pilz	2002/0145394 A1	10/2002	Morgan et al.
7,262,439 B2	8/2007	Setlur et al.	2002/0145869 A1	10/2002	Dowling
7,264,372 B2	9/2007	Maglica	2002/0152045 A1	10/2002	Dowling et al.
7,267,467 B2	9/2007	Wu et al.	2002/0152298 A1	10/2002	Kikita et al.

2002/0153851	A1	10/2002	Morgan et al.	2005/0162093	A1	7/2005	Timmermans et al.
2002/0158583	A1	10/2002	Lys et al.	2005/0174473	A1	8/2005	Morgan et al.
2002/0163316	A1	11/2002	Lys et al.	2005/0174780	A1	8/2005	Park
2002/0171365	A1	11/2002	Morgan et al.	2005/0184667	A1	8/2005	Sturman et al.
2002/0171377	A1	11/2002	Mueller et al.	2005/0201112	A1	9/2005	Machi et al.
2002/0171378	A1	11/2002	Morgan et al.	2005/0206529	A1	9/2005	St.-Germain
2002/0176259	A1	11/2002	Ducharme	2005/0213320	A1	9/2005	Kazuhiro et al.
2002/0179816	A1	12/2002	Haines et al.	2005/0213352	A1	9/2005	Lys
2002/0195975	A1	12/2002	Schanberger et al.	2005/0213353	A1	9/2005	Lys
2003/0011538	A1	1/2003	Lys et al.	2005/0218838	A1	10/2005	Lys
2003/0028260	A1	2/2003	Blackwell	2005/0218870	A1	10/2005	Lys
2003/0031015	A1	2/2003	Ishibashi	2005/0219860	A1	10/2005	Schexnaider
2003/0057884	A1	3/2003	Dowling et al.	2005/0219872	A1	10/2005	Lys
2003/0057886	A1	3/2003	Lys et al.	2005/0225979	A1	10/2005	Robertson et al.
2003/0057887	A1	3/2003	Dowling et al.	2005/0231133	A1	10/2005	Lys
2003/0057890	A1	3/2003	Lys et al.	2005/0236029	A1	10/2005	Dowling
2003/0076281	A1	4/2003	Morgan et al.	2005/0236998	A1	10/2005	Mueller et al.
2003/0085710	A1	5/2003	Bourgault et al.	2005/0248299	A1	11/2005	Chemel et al.
2003/0095404	A1	5/2003	Becks et al.	2005/0253533	A1	11/2005	Lys et al.
2003/0100837	A1	5/2003	Lys et al.	2005/0259424	A1	11/2005	Zampini, II et al.
2003/0102810	A1	6/2003	Cross et al.	2005/0265019	A1	12/2005	Sommers et al.
2003/0133292	A1	7/2003	Mueller et al.	2005/0275626	A1	12/2005	Mueller et al.
2003/0137258	A1	7/2003	Pieprgras et al.	2005/0276051	A1	12/2005	Caudle et al.
2003/0185005	A1	10/2003	Sommers et al.	2005/0276053	A1	12/2005	Nortrup et al.
2003/0185014	A1	10/2003	Gloisten	2005/0276064	A1	12/2005	Wu et al.
2003/0189412	A1	10/2003	Cunningham	2005/0285547	A1	12/2005	Pieprgras et al.
2003/0222587	A1	12/2003	Dowling, Jr. et al.	2006/0002110	A1	1/2006	Dowling et al.
2004/0003545	A1	1/2004	Gillespie	2006/0012987	A9	1/2006	Ducharme et al.
2004/0012959	A1	1/2004	Robertson et al.	2006/0012997	A1	1/2006	Catalano et al.
2004/0036006	A1	2/2004	Dowling	2006/0016960	A1	1/2006	Morgan et al.
2004/0037088	A1	2/2004	English et al.	2006/0022214	A1	2/2006	Morgan et al.
2004/0052076	A1	3/2004	Mueller et al.	2006/0028155	A1	2/2006	Young
2004/0062041	A1	4/2004	Cross et al.	2006/0028837	A1	2/2006	Mrakovich
2004/0075572	A1	4/2004	Buschmann et al.	2006/0034078	A1	2/2006	Kovacik et al.
2004/0080960	A1	4/2004	Wu	2006/0050509	A9	3/2006	Dowling et al.
2004/0090191	A1	5/2004	Mueller et al.	2006/0050514	A1	3/2006	Opolka
2004/0090787	A1	5/2004	Dowling et al.	2006/0076908	A1	4/2006	Morgan et al.
2004/0105261	A1	6/2004	Ducharme et al.	2006/0092640	A1	5/2006	Li
2004/0113568	A1	6/2004	Dowling et al.	2006/0098077	A1	5/2006	Dowling
2004/0116039	A1	6/2004	Mueller et al.	2006/0104058	A1	5/2006	Chemel et al.
2004/0124782	A1	7/2004	Yu	2006/0109648	A1	5/2006	Trenchard et al.
2004/0130908	A1*	7/2004	McClurg et al. .... 362/555	2006/0109649	A1	5/2006	Ducharme et al.
2004/0130909	A1	7/2004	Mueller et al.	2006/0109661	A1	5/2006	Coushaine et al.
2004/0141321	A1	7/2004	Dowling et al.	2006/0126325	A1	6/2006	Lefebvre et al.
2004/0155609	A1	8/2004	Lys et al.	2006/0132061	A1	6/2006	McCormick et al.
2004/0160199	A1	8/2004	Morgan et al.	2006/0132323	A1	6/2006	Grady, Jr.
2004/0178751	A1	9/2004	Mueller et al.	2006/0146531	A1	7/2006	Reo et al.
2004/0189218	A1	9/2004	Leong et al.	2006/0152172	A9	7/2006	Mueller et al.
2004/0189262	A1	9/2004	McGrath	2006/0158881	A1	7/2006	Dowling
2004/0212320	A1	10/2004	Dowling et al.	2006/0170376	A1	8/2006	Pieprgras et al.
2004/0212321	A1	10/2004	Lys et al.	2006/0192502	A1	8/2006	Brown et al.
2004/0212993	A1	10/2004	Morgan et al.	2006/0193131	A1	8/2006	McGrath et al.
2004/0223328	A1	11/2004	Lee et al.	2006/0197661	A1	9/2006	Tracy et al.
2004/0240890	A1	12/2004	Lys et al.	2006/0198128	A1	9/2006	Pieprgras et al.
2004/0257007	A1	12/2004	Lys et al.	2006/0208667	A1	9/2006	Lys et al.
2005/0013133	A1	1/2005	Yeh	2006/0221606	A1	10/2006	Dowling et al.
2005/0024877	A1	2/2005	Frederick	2006/0221619	A1	10/2006	Nishigaki
2005/0030744	A1	2/2005	Ducharme et al.	2006/0232974	A1	10/2006	Lee et al.
2005/0035728	A1	2/2005	Schanberger et al.	2006/0262516	A9	11/2006	Dowling et al.
2005/0036300	A1	2/2005	Dowling et al.	2006/0262521	A1	11/2006	Pieprgras et al.
2005/0040774	A1	2/2005	Mueller et al.	2006/0262544	A1	11/2006	Pieprgras et al.
2005/0041161	A1	2/2005	Dowling et al.	2006/0262545	A1	11/2006	Pieprgras et al.
2005/0041424	A1	2/2005	Ducharme	2006/0273741	A1	12/2006	Stalker, III
2005/0043907	A1	2/2005	Eckel et al.	2006/0274529	A1	12/2006	Cao
2005/0044617	A1	3/2005	Mueller et al.	2006/0285325	A1	12/2006	Ducharme et al.
2005/0047132	A1	3/2005	Dowling et al.	2007/0035255	A1	2/2007	Shuster et al.
2005/0047134	A1	3/2005	Mueller et al.	2007/0040516	A1	2/2007	Chen
2005/0062440	A1	3/2005	Lys et al.	2007/0041220	A1	2/2007	Lynch
2005/0063194	A1	3/2005	Lys et al.	2007/0047227	A1	3/2007	Ducharme
2005/0078477	A1	4/2005	Lo	2007/0053182	A1	3/2007	Robertson
2005/0099824	A1	5/2005	Dowling et al.	2007/0053208	A1	3/2007	Justel et al.
2005/0107694	A1	5/2005	Jansen et al.	2007/0064419	A1	3/2007	Gandhi
2005/0110384	A1	5/2005	Peterson	2007/0070621	A1	3/2007	Rivas et al.
2005/0116667	A1	6/2005	Mueller et al.	2007/0070631	A1	3/2007	Huang et al.
2005/0128751	A1	6/2005	Roberge et al.	2007/0081423	A1	4/2007	Chien
2005/0141225	A1	6/2005	Striebel	2007/0086754	A1	4/2007	Lys et al.
2005/0151489	A1	7/2005	Lys et al.	2007/0086912	A1	4/2007	Dowling et al.
2005/0151663	A1	7/2005	Tanguay	2007/0097678	A1	5/2007	Yang
2005/0154494	A1	7/2005	Ahmed	2007/0115658	A1	5/2007	Mueller et al.



KR	10-2004-0008244	A	1/2004
KR	20-0430022	Y1	11/2006
KR	10-0781652	B1	12/2007
WO	99/10867	A1	3/1999
WO	99/31560	A2	6/1999
WO	00/01067	A2	1/2000
WO	02/25842	A2	3/2002
WO	02/061330	A2	8/2002
WO	02/069306	A2	9/2002
WO	02/091805	A2	11/2002
WO	02/098182	A2	12/2002
WO	02/099780	A2	12/2002
WO	03/026358	A1	3/2003
WO	03/055273	A2	7/2003
WO	03/067934	A2	8/2003
WO	03/090890	A1	11/2003
WO	03/096761	A1	11/2003
WO	2004/021747	A2	3/2004
WO	2004/023850	A2	3/2004
WO	2004/032572	A2	4/2004
WO	2004/100624	A2	11/2004
WO	2005/052751	A2	6/2005
WO	2005/060309	A2	6/2005
WO	2005/084339	A2	9/2005
WO	2005/089293	A2	9/2005
WO	2005/089309	A2	9/2005
WO	2006/023149	A2	3/2006
WO	2006/093889	A2	9/2006
WO	2006/127666	A2	11/2006
WO	2006/127785	A2	11/2006
WO	2006/133272	A2	12/2006
WO	2007/081674	A1	7/2007
WO	2007/094810	A2	8/2007

## OTHER PUBLICATIONS

EXPERIMENT Electronic Ballast. Electronic Ballast for Fluorescent Lamps [online], Revised Fall of 2007. [Retrieved on Sep. 1, 1997]. Retrieved from Virginia Tech Web Page using Internet <URL: <http://www.ece.vt.edu/ece3354/labs/ballast.pdf>>.

TRUCK-LITE, LEDSelect—LED, Model 35, Clearance & Marker Lighting, [online], [retrieved on Jan. 13, 2000] Retrieved from Truck-Lite Web Page using Internet <URL: <http://trucklite.com/leds14.html>>.

TRUCK-LITE, LEDSelect—LED, Super 44, Stop, Turn & Tail Lighting, [online], [retrieved on Jan. 13, 2000] Retrieved from Truck-Lite Web Page using Internet <URL: <http://trucklite.com/leds2.html>>.

TRUCK-LITE, LEDSelect—LED, Model 45, Stop, Turn & Tail Lighting [online], [retrieved on Jan. 13, 2000] Retrieved from Truck-Lite Web Page using Internet <URL: <http://trucklite.com/leds4.html>>.

TELECITE Products & Services—Display Options, [online], [retrieved on Jan. 13, 2000] Retrieved from Telecite Web page using Internet <URL: <http://www.telecite.com/en/products/options.en.htm>>.

Traffic Signal Products—Transportation Products Group, [online], [retrieved on Jan. 13, 2000] Retrieved from the Dialight Web Page using Internet <URL: <http://www.dialight.com/trans.htm>>.

LED Lights, Replacement LED lamps for any incandescent light, [online], [retrieved on Jan. 13, 2000] Retrieved from LED Lights Web Page using Internet <URL: <http://www.ledlights.com/replac.htm>>.

LEDTRONICS, LEDTRONICS Catalog, 1996, p. 10, LEDTRONICS, Torrance, California.

Piper. The Best Path to Efficiency. Building Operating Management, Trade Press Publishing Company May 2000 [online], [retrieved on Jan. 17, 2008]. Retrieved from Find Articles Web Page using Internet <URL: [http://findarticles.com/p/articles/mi\\_qu3922/is\\_200005/ai\\_n8899499/](http://findarticles.com/p/articles/mi_qu3922/is_200005/ai_n8899499/)>.

Henson, Keith. The Benefits of Building Systems Integration. Access Control & Security Systems Integration, Oct. 1, 2000, Penton Media. [online], [retrieved on Oct. 24, 2008] Retrieved from Security Solutions Web page using Internet <URL: [http://securitysolutions.com/mag/security\\_benefits\\_building\\_systems/](http://securitysolutions.com/mag/security_benefits_building_systems/)>.

Phason Electronic Control Systems, Light Level Controller (LLC) case study. Nov. 30, 2004. 3 pages, Phason Inc., Winnipeg, Manitoba, Canada.

Airport International. Fly High With Intelligent Airport Building and Security Solutions [online], [retrieved on Oct. 24, 2008]. Retrieved from Airport International web page using Internet <URL: <http://www.airport-int.com/categories/airport-building-and-security-solutions/fly-high-with-intelligent-airport-building-and-security-solutions.html>>.

Spencer, Eugene. High Sales, Low Utilization. Green Intelligent Buildings, Feb. 1, 2007. [online]. Retrieved from Green Intelligent Buildings web page using Internet <URL: [http://www.greenintelligentbuildings.com/CDA/IBT\\_Archive/BNP\\_GUID\\_9-5-2006\\_A\\_10000000000000056772](http://www.greenintelligentbuildings.com/CDA/IBT_Archive/BNP_GUID_9-5-2006_A_10000000000000056772)>.

Lawrence Berkeley National Laboratory. Lighting Control System—Phase Cut Carrier. University of California, [online] [retrieved on Jan. 14, 2008] Retrieved from Lawrence Berkeley National Laboratory web page using Internet <URL: <http://www.lbl.gov/tt/techs/lbn11871.html>>.

D.N.A.-111, [online], [retrieved Mar. 10, 2009] Retrieved from the PLC Lighting Web Page using Internet <URL: [http://www.plclighting.com/product\\_info.php?cPath=1&products\\_id=92](http://www.plclighting.com/product_info.php?cPath=1&products_id=92)>.

E22201-44 Esprit Collection, [online], [retrieved on Jul. 10, 2010] Retrieved from ET2 Contemporary Lighting using Internet <URL: <http://www.et2online.com/proddetail.aspx?ItemID=E22201-44>>.

E20116-18 Larmes Collection, [online], [retrieved on Jul. 10, 2010] Retrieved from ET2 Contemporary Lighting using Internet <URL: <http://www.et2online.com/proddetail.aspx?ItemID=E20116-18>>.

E20112-22 Starburst Collection, [online], [retrieved on Jul. 10, 2010] Retrieved from ET2 Contemporary Lighting using Internet <URL: <http://www.et2online.com/proddetail.aspx?ItemID=E20112-22>>.

E20743-09 Stealth Collection, [online], [retrieved on Jul. 10, 2010] Retrieved from ET2 Contemporary Lighting using Internet <URL: <http://www.et2online.com/proddetail.aspx?ItemID=E20743-09>>.

E20524-10 & E20525-10 Curva Collection, [online], [retrieved on Jul. 10, 2010] Retrieved from ET2 Contemporary Lighting using Internet <URL: <http://www.et2online.com/proddetail.aspx?ItemID=E20524-10&E20525-10>>.

\* cited by examiner



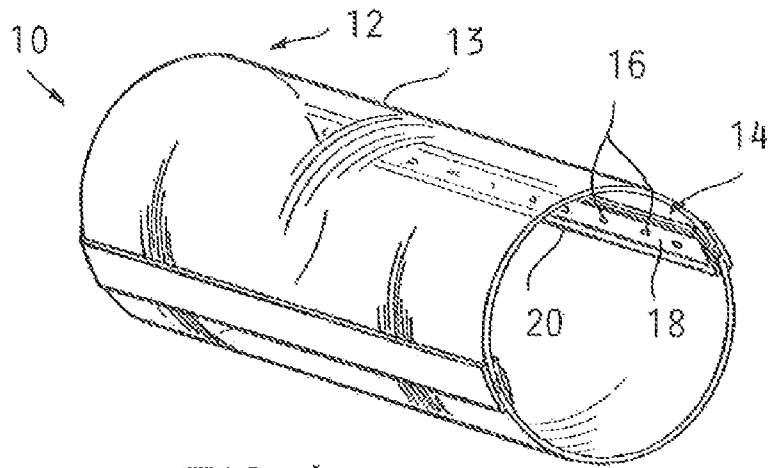

FIG. 1

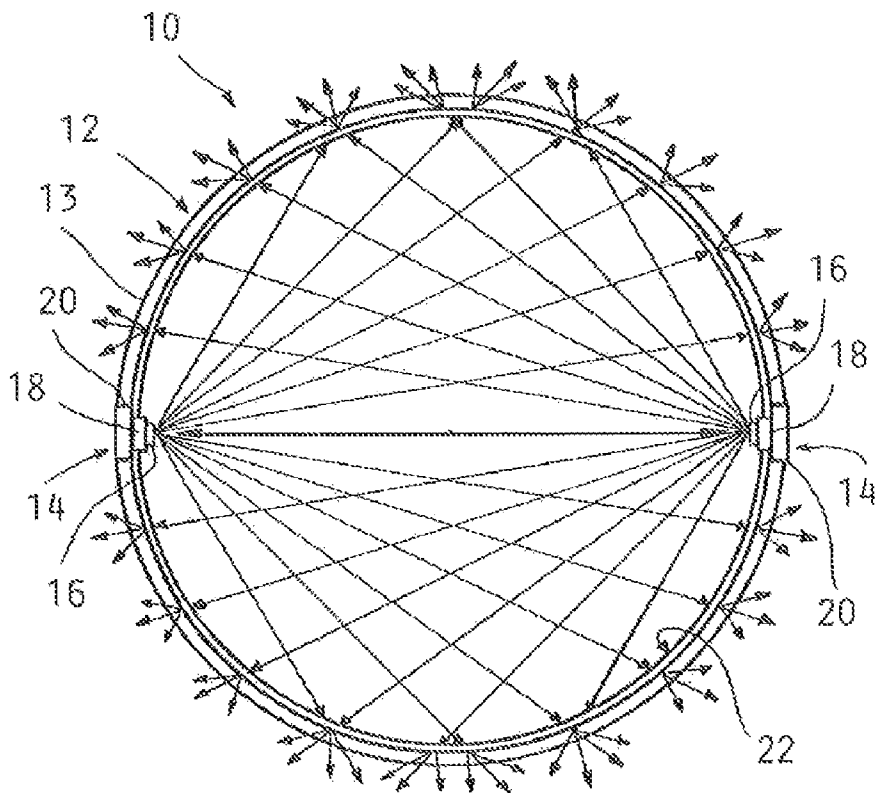

FIG. 2

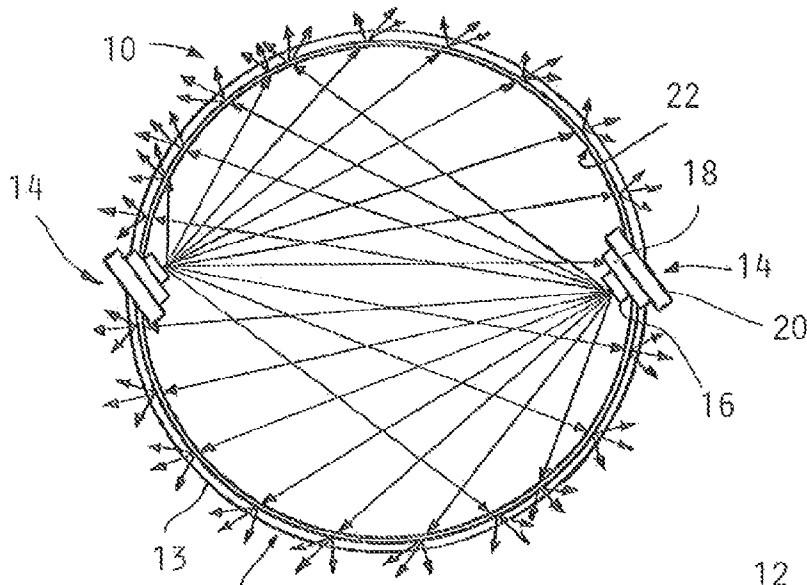

FIG. 3

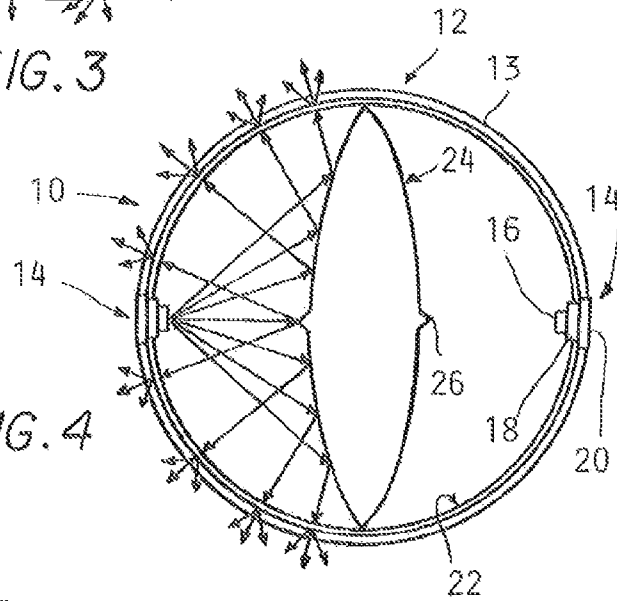

FIG. 4

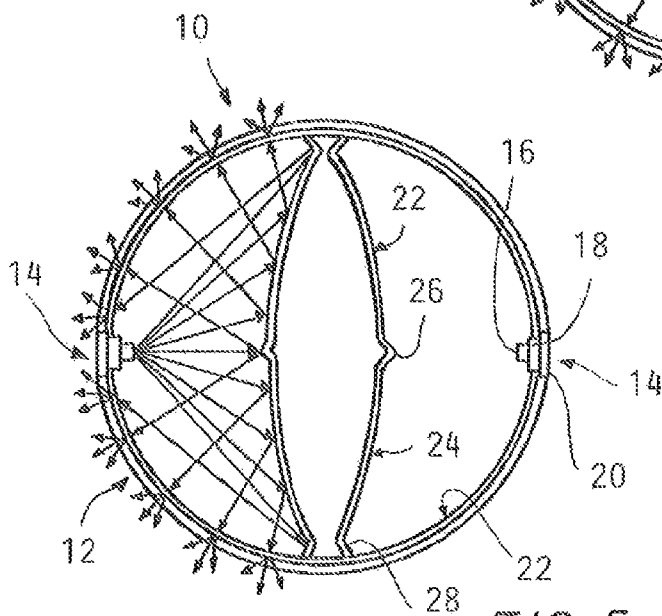

FIG. 5

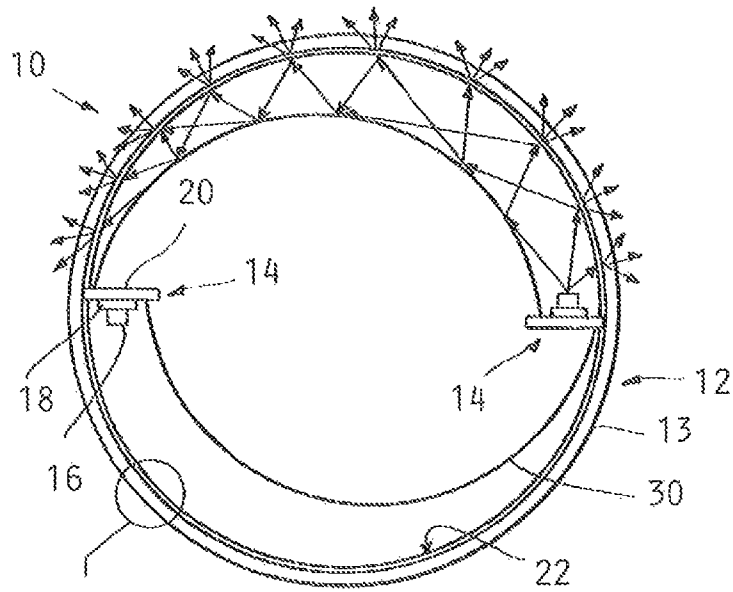

FIG. 6A

FIG. 6

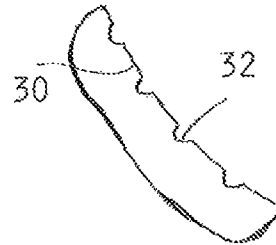

FIG. 6A

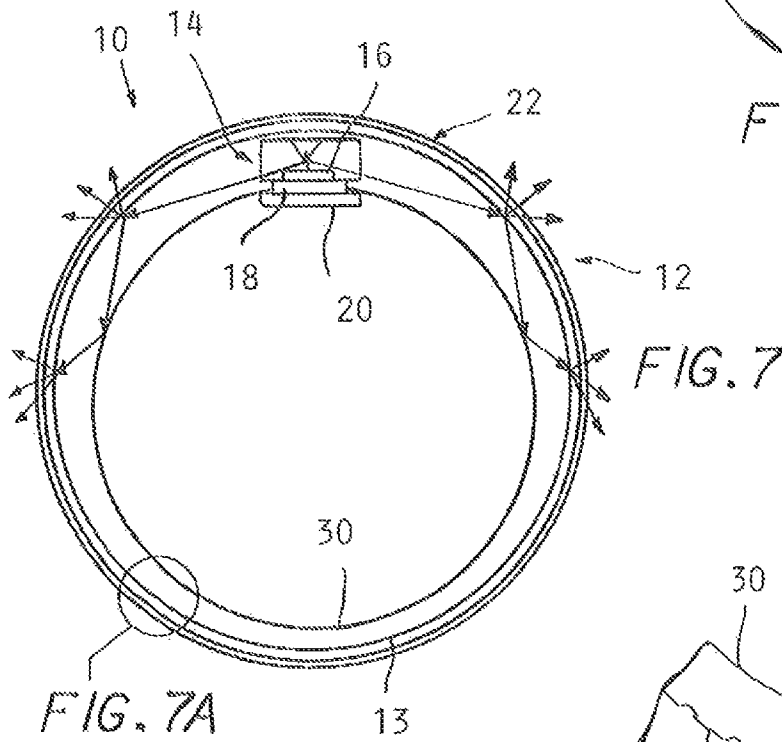

FIG. 7A

FIG. 7

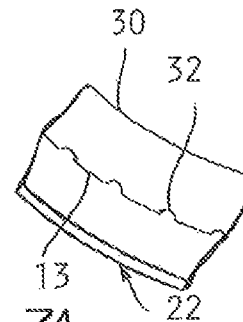

FIG. 7A

1

## LIGHT DISTRIBUTION USING A LIGHT EMITTING DIODE ASSEMBLY

### CROSS-REFERENCE TO RELATED APPLICATION

This application is a continuation of U.S. patent application Ser. No. 11/962,995, filed Dec. 21, 2007, now U.S. Pat. No. 7,712,918.

### TECHNICAL FIELD

The present invention relates to a light emitting diode (LED) assembly, and more specifically, to a LED assembly that can replace a conventional fluorescent light in a conventional fluorescent light fixture.

### BACKGROUND

Light emitting diodes (LEDs) have many advantages over fluorescent lights. LEDs are more efficient, last longer, and are less sensitive to vibrations and low temperatures. To take advantage of the benefits of LEDs, conventional fluorescent light tubes have been retrofit to include LEDs. For example, U.S. Pat. No. 7,049,761 discloses a tube having the shape of a conventional fluorescent light tube encasing a group of LEDs. Known fluorescent light tubes retrofit with LEDs are constrained by the directional light output of the LEDs, in contrast to the uniform non-directional light output of fluorescent tubes.

### BRIEF SUMMARY

The present invention teaches LEDs in various orientations to evenly distribute light around the circumference and along the length of a tube, resulting in even lighting without obvious point sources of light. One such configuration includes a first LED assembly and a second LED assembly, each having a plurality of LEDs. A tube includes at least one tube portion, and the first and second LED assemblies are attached to longitudinal lengths of the tube portion and are oriented to face the interior of the tube. The areas of the tube that receive the least amount of light from each LED assembly receive light from multiple LED assemblies, while the sections of the tube that receive the greatest amount of light from each LED assembly only receive light from one LED assembly. Thus, in the aggregate, a similar amount of light strikes the tube around its entire circumference and along its entire length.

Another such configuration includes, for example, a tubular housing including at least one tube portion and at least one LED assembly including a plurality of LEDs. Each LED assembly is mounted to a longitudinal length of the tubular housing and is oriented to emit light parallel to a tangent of the tubular housing. This configuration also includes a light pipe associated with each LED assembly and curving inside at least a portion of the tubular housing.

Details of these embodiments, and others, are described in further detail hereinafter.

### BRIEF DESCRIPTION OF THE DRAWINGS

The description herein makes reference to the accompanying drawings wherein like reference numerals refer to like parts throughout the several views, and wherein:

FIG. 1 is an isometric view of a transparent tube with two center-facing LED assemblies mounted along longitudinal lengths of the tube;

2

FIG. 2 is a side view of a tube with two center-facing LED assemblies mounted along longitudinal lengths of the tube;

FIG. 3 is a side view of a tube with two offset LED assemblies mounted along longitudinal lengths of the tube;

FIG. 4 is a side view of a tube with two center-facing LED assemblies and a reflecting surface positioned between the two LED assemblies;

FIG. 5 is a side view of a tube similar to the tube shown in FIG. 4, but the reflecting surface has bends to direct light back toward the perimeters of the LED assemblies;

FIG. 6 is a side view of a tube with two radially mounted LED assemblies and two light pipes to direct light around an arc of the tube;

FIG. 6A is a partial fragmentary view of FIG. 6;

FIG. 7 is a side view of a tube with a side-emitting LED and a light pipe; and

FIG. 7A is a partial fragmentary view of FIG. 7.

### DETAILED DESCRIPTION OF EMBODIMENTS OF THE INVENTION

Known fluorescent light tubes retrofit with LEDs distribute light directly toward objects to be illuminated. However, distributing light directly toward objects to be illuminated can result in harsh, uneven light and the appearance of bright spots due to the narrow viewing angle of LEDs. In contrast, embodiments of a linear distribution light emitting diode assembly that provide even light are disclosed herein. By placing LEDs in certain orientations, the appearance of bright spots is overcome, and even light is provided.

Embodiments of a linear distribution light emitting diode assembly are illustrated in FIGS. 1-7. The light rays illustrated in the figures are for illustrative purposes only and are not intended to accurately portray the actual dispersion of light from the LEDs. As illustrated in FIG. 1, an LED lighting unit 10 includes a tube 12 and a LED assembly 14. The tube 12 is shaped to enable the LED lighting unit 10 to be compatible with a conventional fluorescent light fixture and includes end caps for inserting the unit 10 into such a light fixture. The LED assemblies 14 extend along longitudinal lengths of the tube 12, i.e., lengths of the tube 12 parallel to the axis of the tube 12, in order to provide light to the entire length of the tube 12. The tube 12 is formed by attaching two semi-circular tube portions 13 to the LED assemblies 14. The attachment between the tube portions 13 and the LED assemblies 14 can be by way of glue, screws, snap-fit mechanisms, or other suitable attachment mechanisms known to those of skill in the art.

If, however, the LED lighting unit 10 includes only one LED assembly 14 on a circumference of the tube 12 as illustrated in FIG. 7, one tube portion 13 can extend nearly a full circle from one side of the LED assembly 14 to the other. Alternatively, the tube 12 can be a conventional fluorescent light tube with LED assemblies 14 attached to its interior as illustrated by example in FIG. 5. The attachment between the tube 12 and the LED assemblies 14 can be by way of glue, screws, snap-fit mechanisms, or other suitable attachment mechanisms known to those of skill in the art. Also, the specific shape of the tube 12 depends on the desired use of the LED lighting unit 10. For example, the tube 12 need not be an elongated shape; it can be U-shaped, toroidal, or any other shaped required by the specific application. In such a case, the one or more LED assemblies 14 would still extend parallel to the axis of the tube (that is, would still extend in a longitudinal direction), but would be shaped to be compatible with the tube 12. For example, if the tube 12 is intended to replace a conventional ring-shaped fluorescent light, the LED assemblies

**14** extend longitudinally around the inner and outer circumferences of the ring-shaped tube to follow the curve of the tube **12**. The tube **12** can be formed of polycarbonate, glass, acrylic, and other materials known to those of skill in the art.

In the illustrated FIG. 2, the tube **12** includes a diffusing surface **22**. The diffusing surface **22** as illustrated is a diffusing film applied to the interior surface of the tube **12**. Alternatively, the diffusing surface can include light diffusing particles in a light transmitting resin applied to the interior of a transparent tube **12**. Or, instead of fixing a separate diffusing layer to a transparent tube, the tube **10** can be made of a translucent material. The tube **12** can also undergo a treatment to create a diffusing surface **22** on its interior, such as roughening the interior surface of the tube **12**. Alternatively, as illustrated in FIG. 7, light extraction structures, such as ridges **32**, dots, bumps, dimples, and other uneven surfaces, can be included on the interior surface of the tube **12**, in which case a separate diffusing layer can be included on the exterior of the tube **12**.

Each LED light assembly **14** includes a plurality of LEDs **16** and an electric circuit. The LEDs **16** included in the LED light assembly **14** emit white light. However, if desired, LEDs **16** that emit blue light, ultra-violet light or other wavelengths of light can be included. Printed circuit boards (PCB) **18** make up the electric circuitry in the illustrated embodiments. However, other types of circuit boards, for example metal core circuit boards, can be used in place of PCBs **18**. Alternatively, the circuitry can be formed directly on the interior surface of the tube **12**, such as by depositing copper onto the interior of the tube portions **13** before assembly. Likewise, wires can be used in place of a printed circuit board **18**, so long as the LEDs **16** are electrically connected and adequately supported. When wires are used, LEDs **16** can be glued directly to a heat sink **20** or, if no heat sink is necessary in the application, to the tube **12**. Because the danger of LED failure is low, the LEDs **16** can be connected in series or parallel. Heat sinks **20** are illustrated attached to each PCB **18**. However, the tube portions **13** can be formed of heat-conducting plastic materials that do not require heat sinks **20**. In an application where the tube **12** is arranged in a ring-shape, for example, it is desirable that the electric circuit include a flexible circuit board.

To facilitate a physical and electrical connection with a conventional fluorescent lighting fixture, end caps (not shown) are attached to each end of the tube **12**. The end caps include a transformer, if necessary, and any other required electrical components. Alternatively, the electrical components can reside in a portion of the tube **12**. The end caps include a necessary physical and electrical connection, such as the two-pin configuration commonly used in conventional fluorescent light fixtures. Such a structure is shown in, for example, U.S. Pat. No. 7,049,761.

In the embodiment illustrated in FIG. 2, two LED assemblies **14** are attached to longitudinal lengths of tube portions **13** to form tube **12**. The LED assemblies **14** are spaced apart 180° relative to the center of the tube **12**, and the LED assemblies **14** are oriented to face the center of the tube **12**. While LEDs **16** emit light in multiple directions, the direction a LED **16** is said to be “facing” is determined by reference to the direction in which emitted light travels. That is, if a line were to run in the direction an LED assembly **14** is oriented to “face”, an equal amount of light emitted by the LED **16** would pass on both sides of any plane including the line.

The light emitted by an LED **16** is the most concentrated in the region surrounding the direction the LED **16** faces. By placing two LED assemblies **14** on opposite sides of the tube **12** and orienting them to face the center of the tube **12**, an even

distribution of light around the circumference of the tube **12** is achieved because the parts of the tube **12** that receive the least amount of light from each LED assembly **14**, such as the top and bottom portions of the tube **12** as shown in FIG. 2, receive light from both LED assemblies **14**. The parts of the tube **12** that receive the most amount of light from each LED assembly **14**, such as the area of the tube **12** in the region around where the LED **16** faces, only receive light from one LED assembly **14**. Thus, in the aggregate, a similar amount of light strikes the tube **12** around its entire circumference. Further, the diffusing surface **22** provides additional bright-spot eliminating capability by diffusing the light before it exits the tube **12**. While only two LED assemblies **14** are contemplated on a single circumferential path of the tube **12** in the embodiment illustrated in FIG. 2, additional LED assemblies **14** could be placed about the tube **12** for additional brightness. It is desirable but not necessary that such LED assemblies **14** be evenly-spaced about the tube **12**.

A second embodiment is illustrated in FIG. 3. Here, the LED assemblies **14** are in an offset orientation; i.e., instead of facing the center of the tube **12**, the LED assemblies **14** in FIG. 3 are angled slightly above and below the center of the tube **12**, respectively. The LED assembly **14** orientation in the first embodiment results in some light being blocked from exiting the tube **12** by the opposing LED assembly **14**. Compared to the center-facing orientation of the first embodiment, the offset orientation of the second embodiment permits an increased amount of light to exit the tube **12**, resulting in an increased overall brightness of the LED lighting unit **10**. The number of LED assemblies **14** around one circumference of the tube **12** and the spacing of the LED assemblies **14** can be varied from the configuration shown in FIG. 3, but it is desirable that such assemblies **14** be distributed evenly around the circumference of the tube **12** as mentioned above. Additionally, the offset angle, i.e., the angle between the direction a LED **16** faces and the center-facing direction, can be varied. The greater the offset angle, the less light is blocked by the opposing LED assembly **14**. However, the trade-off of increasing the offset angle is that the light distribution becomes less even as the angle increases.

In another embodiment, as shown in FIG. 4, a reflecting surface **24** is placed inside the tube **12**. The reflecting surface **24** is made of a reflective material, such as a mirror made of glass or plastic with a metallic coating on its backside, and can include a diffusing surface if desired. The reflecting surface **24** spans a diameter of the tube **12**. Alternatively, the reflecting surface **24** can have a major length less than the diameter of the tube **12** and can be buttressed by brackets in the tube **12** or attached to end caps at each end of the tube **12**. The reflecting surface **24** has a convex shape designed to evenly distribute light throughout an arc of the tube **12**. The specific curvature of the reflecting surface **24** is dependent on the viewing angle of the LEDs **16**, the distance from each LED **16** to the reflecting surface **24**, and the number of LEDs **16** around the circumference of the tube **12**. For example, a LED **16** with a narrow viewing angle requires a greater angle of deflection than a LED **16** with a wide viewing angle in order to achieve the same distribution of light across an arc of the tube **12**. Additionally, a lip **26** projects from the reflecting surface **24** near the point where each LED **16** faces the reflecting surface **24**. The lip **26** is a projection from the reflecting surface **24** that directs light around the LED assembly **14** that would otherwise be reflected off the reflecting surface **24** right back toward the LED assembly **14**. Thus, the lip **26** increases the amount of light that is able to exit the tube **12**, thereby increasing the brightness of the LED lighting unit **10**.

5

Another embodiment includes a bend **28** in the reflecting surface **24** as illustrated FIG. 5. The reflecting surface **24** in this embodiment is similar to the reflecting surface **24** in the previous embodiment, except bends **28** are disposed near the junction of the reflecting surface **24** and the tube **12**. Each bend **28** is angled to direct light through the area of the tube **12** just outside the perimeter of an LED assembly **14**. By directing light through the tube **12** in the vicinity of the LED assembly **14**, the occurrence of dark spots created by the LED assemblies **14** is reduced. This embodiment also features a diffusing surface **22** on the reflecting surface **24**.

An embodiment illustrated in FIG. 6 features at least one LED assembly **14** mounted radially to the tube **12**. In this orientation, the radially-mounted LED assembly **14** faces parallel to a tangent of the tube **12** at the location the LED assembly **14** is mounted. A first end of a light pipe **30** is adjacent to each LED **16** to receive the emitted light. The pipe **30** then curves around the inside of the tube **12** until the second end of the pipe **30** is adjacent to the backside of the next LED assembly **14**. The light pipe **30** tapers as it arcs around the circumference of the tube **12**. The large cross section of the light pipe **30** in the vicinity of LED **16** allows a high proportion of light to arc around the tube **12** instead of exiting. As the light arcs around the tube **12** and the quantity of light in the light pipe **30** decreases due to a portion of the light exiting the tube **12**, the smaller cross section of the light pipe **30** forces a higher proportion of light out of the tube **12**. Thus, an even amount of light exits the tube **12** through the entire arc of the tube **12**. The light pipe **30** is constructed of plastic with a metallic coating to reflect light. The light pipe **30** can also be constructed of mirrored glass. Regardless of the material selected, the light pipe **30** should have as close to total internal reflection as possible in order to maximize the brightness of the LED lighting unit **10**.

The surface of the light pipe **30** in this embodiment includes light extraction structures, specifically ridges **32** as illustrated. Light extraction structures can take other shapes, such as dots, bumps, dimples, and other uneven surfaces. The size and shape of such light extracting structures can vary over a circumference and a length of the tube **12** to create a uniform distribution of light over the circumference and length of the tube **12**. For example, the structures can be small and sparse near the LED **16** where the flux of light is high, and larger and more dense away from the LED **16** where the flux of light is low. If multiple LEDs **16** are placed around a circumference of the tube **12**, there can be multiple areas around the circumference of the tube **12** that have densely spaced light extracting structures. The placement of light extracting structures is determined by software, such as the software disclosed in Michael Zollers, "Integrated Optimization Capabilities Provide a Robust Tool for LED Backlight Design," LEDs Magazine (October 2006), pp. 27-29, which is hereby incorporated by reference. The light extracting structure placement can also be determined in other ways, such as through experimentation or hand calculation. Alternatively, the surface of the light pipe **30** can be smooth; the light pipe **30** need not include light extraction structures.

If there is only one LED assembly **14** on a circumference of the tube **12**, the light pipe **30** completes almost an entire rotation inside the tube **12** before ending on the opposite side of the LED assembly **14** from which it started, thereby distributing light over nearly the entire circumference of the tube **12**. In operation, a portion of the light emitted by an LED **16** hits the tube **12** having an angle of incidence less than the critical angle of the tube **12** and exits the tube **12**, a portion hits the tube **12** having an angle of incidence equal to or greater than the critical angle of the tube **12** and is deflected back into the

6

tube **12**, and a portion initially contacts the light pipe **30**. The light pipe **30** deflects the light that hits it back toward the tube **12**. Thus, light rays can ricochet through an arc before exiting the tube **12**, resulting in an even distribution of light through the arc.

An embodiment illustrated in FIG. 7 features a side-emitting LED **16** and a light pipe **30** similar to the light pipe **30** in the fifth embodiment. The side-emitting LED **16** emits a disc of light at approximately a right angle to the direction the LED **16** faces. The LEDs **16** about the tube **12** such that the LEDs **16** emit light parallel to a local tangent of the tube **12**. In this embodiment, the circuit board **18** and heat sink **20** are mounted below the LED **16** on the interior of the tube **12**. Alternatively, the circuit board **18** and heat sink **20** can be mounted on the outside of the tube **12**. The light pipe **30** curves around the inside of the tube **12**, extending from one side of the LED **16** to the other and forming a channel between the tube **12** and the light pipe **30**. The light pipe **30** is tapered such that the portion of the light pipe **30** furthest from the LED **16** is closest to the tube **12**. The tapered shape of the light pipe **30** causes a high proportion of light to exit the tube **12** when the quantity of light is low and results in an even distribution of light around the circumference of the tube **12**. Thus, light exits the side of the LED **16** and curves around a circumference of the tube **12**, reflecting between the tube **12** and the light pipe **30** until the light strikes the tube **12** at an angle less than the critical angle and exits the tube **12**. Alternatively, multiple LED assemblies **14** can be disposed about the circumference of the tube **12**, in which case a light pipe **30** extends between each of the LED assemblies **14**. Also, light extracting structures can be placed on the light pipe **30** as discussed in the previous embodiment.

The above-described embodiments have been described in order to allow easy understanding of the invention and do not limit the invention. On the contrary, the invention is intended to cover various modifications and equivalent arrangements included within the scope of the appended claims, which scope is to be accorded the broadest interpretation so as to encompass all such modifications and equivalent structure as is permitted under the law.

What is claimed is:

1. An LED lighting unit for replacing a conventional fluorescent bulb of a conventional fluorescent lighting fixture comprising:

a tubular housing including at least one tube portion; and a plurality of LED assemblies spaced about a circumference of the tubular housing and extending in a longitudinal direction along the tubular housing; and wherein each of the plurality of LED assemblies includes a plurality of LED devices mounted on a respective mounting surface, and each mounting surface is angled offset from a tangent of the tubular housing that is centered at a mounting location of that mounting surface.

2. The LED lighting unit of claim 1, wherein the plurality of LED assemblies comprises a first LED assembly and a second LED assembly spaced 180° apart about the circumference of the tubular housing.

3. The LED lighting unit of claim 1, further comprising a reflecting surface inside the tubular housing.

4. The LED lighting unit of claim 3, wherein the reflecting surface spans a diameter of the interior of the tube wherein an equal number of LED assemblies are located on the circumference of the tubular housing on each side of the diameter.

5. The LED lighting unit of claim 4, wherein the reflecting surface includes a diffusing surface.

6. The LED lighting unit of claim 1, wherein each tube portion has an arc-shaped cross-section, a transparent outer

7

layer, a diffusing interior layer, and is made of at least one of polycarbonate, acrylic and glass.

7. The LED lighting unit of claim 6, further comprising: a first semicircular tube portion attached to a first LED assembly and a second LED assembly of the plurality of LED assemblies; and

a second semicircular tube portion attached to the first LED assembly and the second LED assembly.

8. The LED lighting unit of claim 1, further comprising: a heat sink attached to each of the plurality of LED assemblies.

9. The LED lighting unit of claim 1, wherein the tubular housing includes one tube portion having a circular cross-section.

10. The LED lighting unit of claim 1, wherein each mounting surface includes a circuit board.

11. The LED lighting unit of claim 1 wherein the tubular housing comprises a single tubular housing having an inner surface and the plurality of LED assemblies is equidistantly spaced about the inner surface of the tubular housing.

12. The LED lighting unit of claim 1 wherein each of the plurality of LED devices is mounted on its respective mounting surface so that its emitted light is oriented to face away from an exterior of the tubular housing at the mounting location of that mounting surface.

13. An LED lighting unit for replacing a conventional fluorescent tube of a conventional fluorescent lighting fixture comprising:

a tubular housing including at least one tube portion and a hollow center;

at least one LED assembly including a plurality of LEDs on a mounting surface, each LED assembly mounted to a

8

longitudinal length of the tubular housing with the mounting surface oriented such that an emitting direction of the plurality of LEDs is parallel to a tangent of the tubular housing, the tangent of the tubular housing being centered at a mounting location of the mounting surface respectively associated with each of the at least one LED assembly; and

a light pipe associated with each LED assembly and having an opening extending radially from an inner surface of the tubular housing, the opening facing the emitting direction of the plurality of LEDs, and the light pipe curving inside the inner surface of the tubular housing and about at least a portion of the hollow center.

14. The LED lighting unit of claim 13, wherein each LED assembly includes a circuit board mounted radially to the longitudinal length of the tubular housing.

15. The LED lighting unit of claim 13, wherein each LED assembly includes a side-emitting LED.

16. The LED lighting unit of claim 13, wherein the surface of the light pipe includes a plurality of light extracting structures.

17. The LED lighting unit of claim 16, wherein the density of light extracting structures on the interior surface of the tubular housing varies over an arc of the light pipe.

18. The LED lighting unit of claim 13, further comprising: a plurality of light extracting structures on the interior surface of the tubular housing; and a diffusing layer on the exterior of the tubular housing.

19. The LED lighting unit of claim 13, further comprising a plurality of LED assemblies equidistantly spaced about the hollow center.

\* \* \* \* \*