



(19) **United States**

(12) **Patent Application Publication**  
**Timmermans et al.**

(10) **Pub. No.: US 2017/0089522 A1**

(43) **Pub. Date: Mar. 30, 2017**

(54) **LIGHT TUBE AND POWER SUPPLY CIRCUIT**

*F21V 23/02* (2006.01)

*F21V 23/00* (2006.01)

*F21V 3/02* (2006.01)

*F21K 9/272* (2006.01)

(71) Applicant: **iLumisys, Inc.**, Troy, MI (US)

(72) Inventors: **Jos Timmermans**, Ortonville, MI (US);  
**Jean C. Raymond**, Nominique (CA);  
**John Ivey**, Farmington Hills, MI (US)

(52) **U.S. Cl.**

CPC ..... *F21K 9/278* (2016.08); *F21V 3/02*

(2013.01); *H05B 33/0845* (2013.01); *H05B*

*33/0815* (2013.01); *F21K 9/272* (2016.08);

*F21V 15/015* (2013.01); *F21V 23/023*

(2013.01); *F21V 23/005* (2013.01); *F21K*

*9/275* (2016.08); *F21Y 2115/10* (2016.08)

(21) Appl. No.: **15/372,082**

(22) Filed: **Dec. 7, 2016**

**Related U.S. Application Data**

(63) Continuation of application No. 15/187,456, filed on Jun. 20, 2016, which is a continuation of application No. 14/865,325, filed on Sep. 25, 2015, now Pat. No. 9,416,923, which is a continuation of application No. 14/669,963, filed on Mar. 26, 2015, now Pat. No. 9,222,626, which is a continuation of application No. 14/299,909, filed on Jun. 9, 2014, now Pat. No. 9,006,990, which is a continuation of application No. 14/299,915, filed on Jun. 9, 2014, now Pat. No. 9,006,993.

**Publication Classification**

(51) **Int. Cl.**

*F21K 9/278* (2006.01)

*H05B 33/08* (2006.01)

*F21K 9/275* (2006.01)

*F21V 15/015* (2006.01)

(57) **ABSTRACT**

A replacement light tube for replacing a fluorescent light tube includes a bulb portion extending between a first end and a second end, the bulb portion comprising a support structure, a plurality of white light emitting diodes (LEDs) and an elongate light-transmissive cover. The support structure has a first surface extending between the first end and the second end. The plurality of LEDs are supported by the first surface and arranged between the first end and the second end. The elongate light-transmissive cover extends between the first end and the second end and over the first surface of the support structure. A first end cap and a second end cap are disposed on the first end and the second end, respectively, each configured to fit with a socket for a fluorescent light tube. A power supply circuit is configured to provide power to the plurality of LEDs. The plurality of LEDs are arranged to emit light through the elongate light-transmissive cover and at least a portion of the power supply circuit is packaged inside at least one of the end caps.

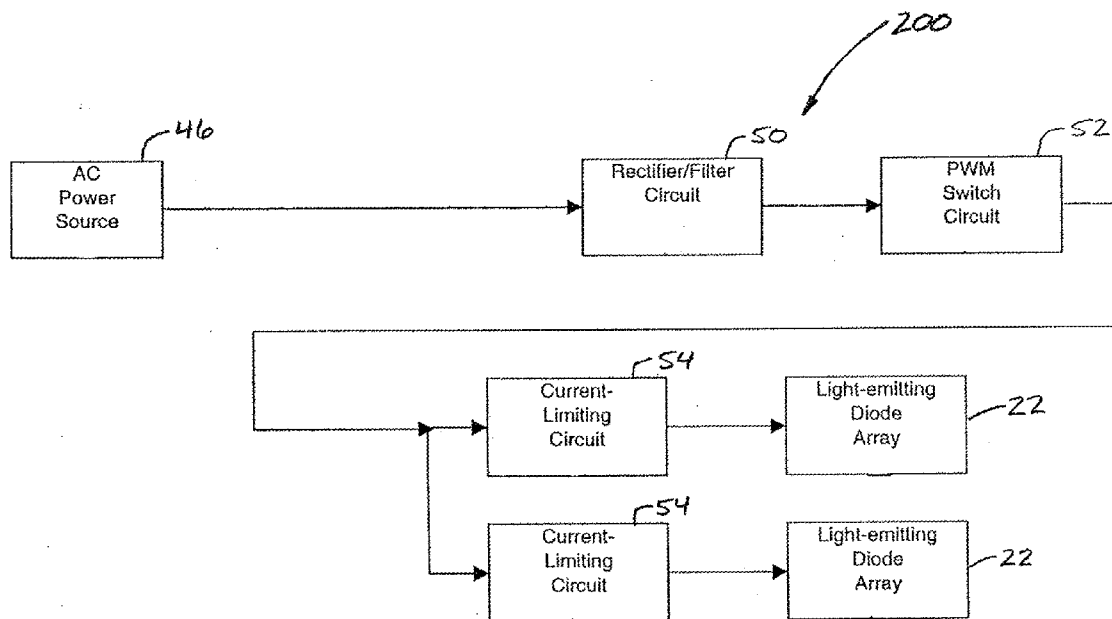

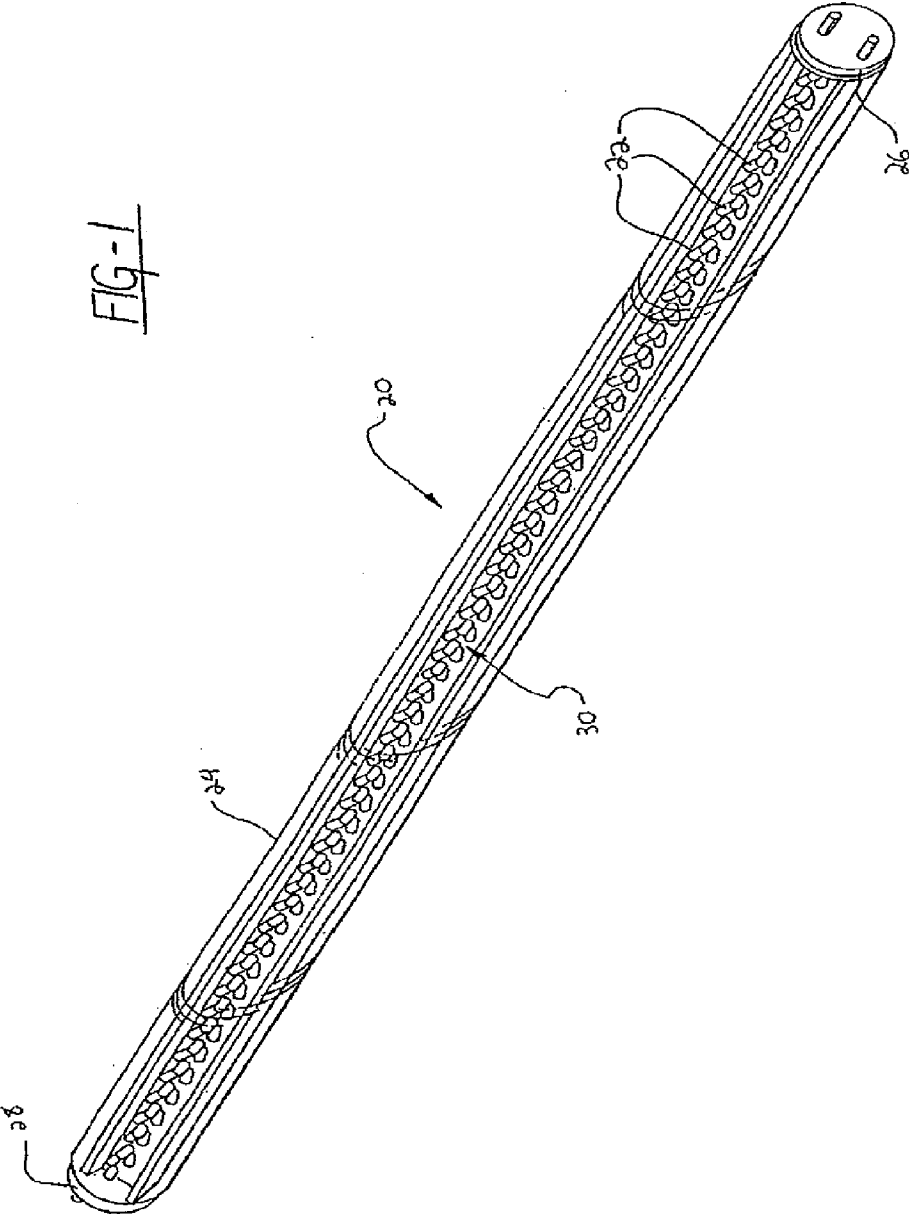

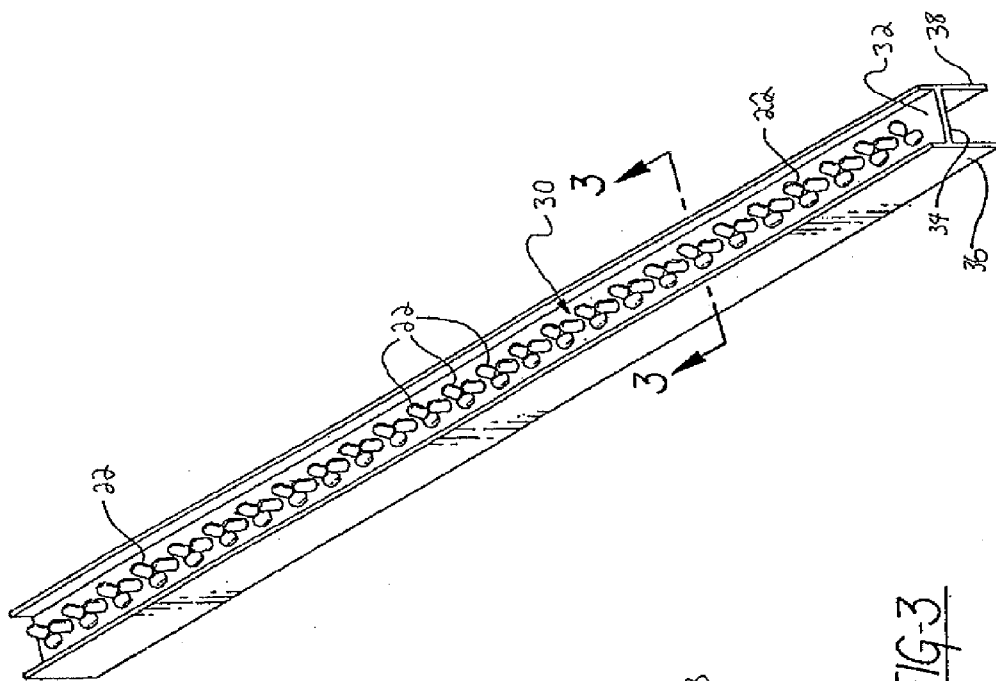

FIG-2

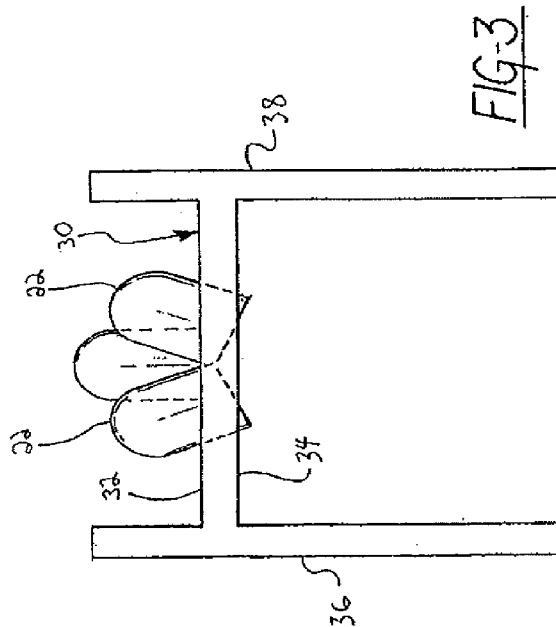

FIG-3

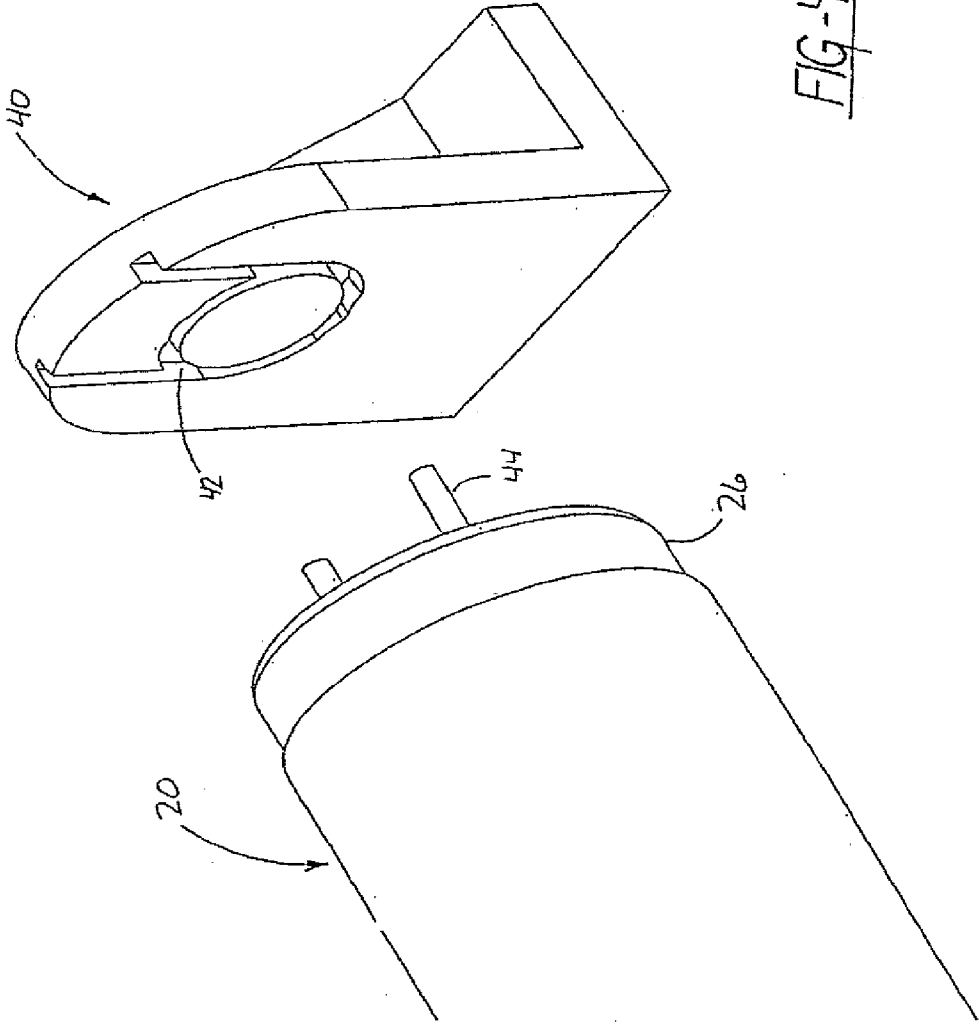

FIG-4

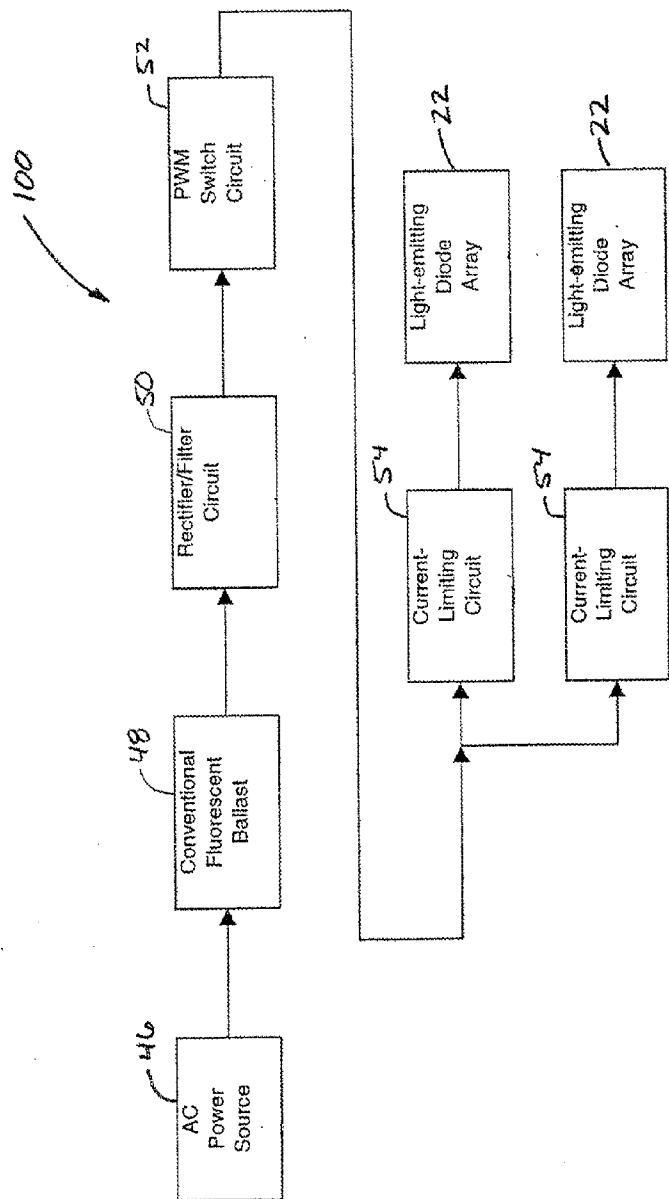

FIG. 5

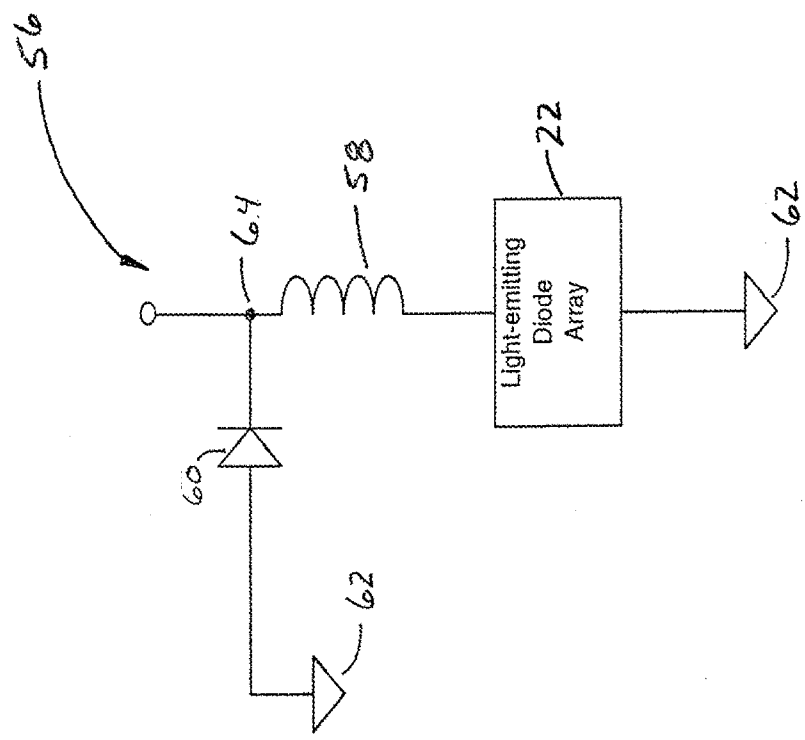

FIG. 6

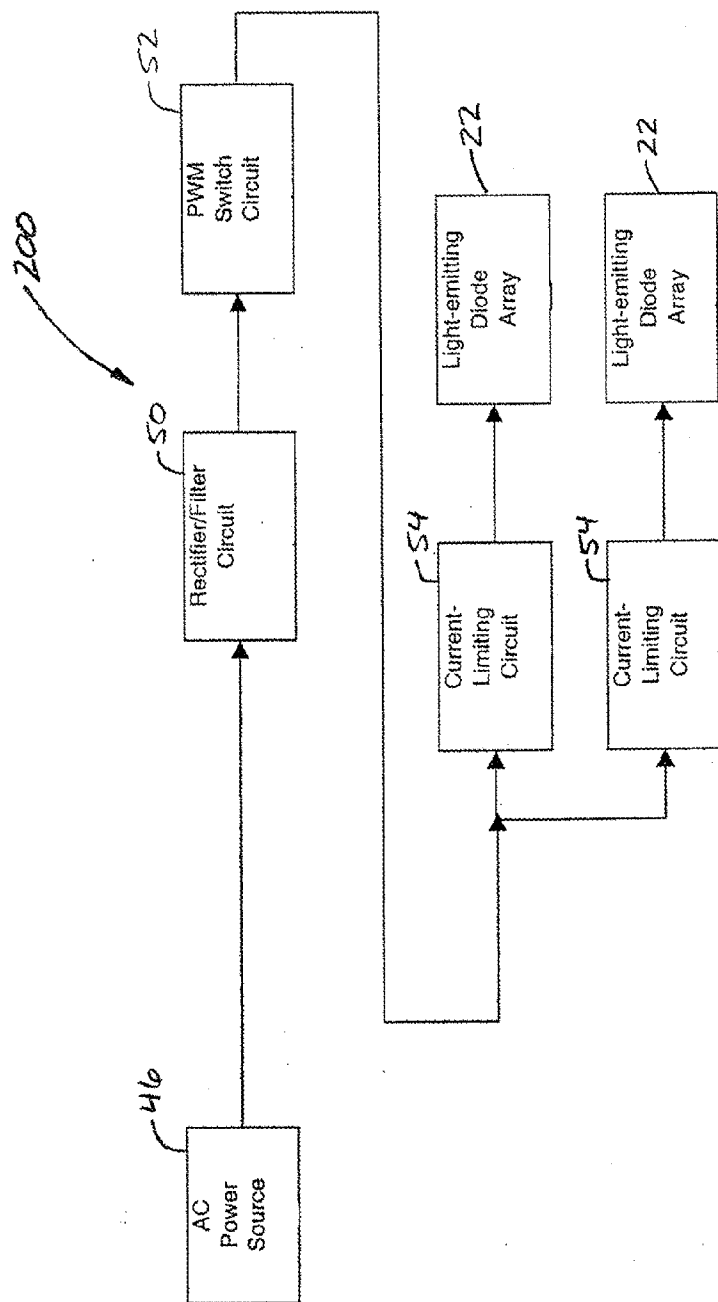

FIG. 7

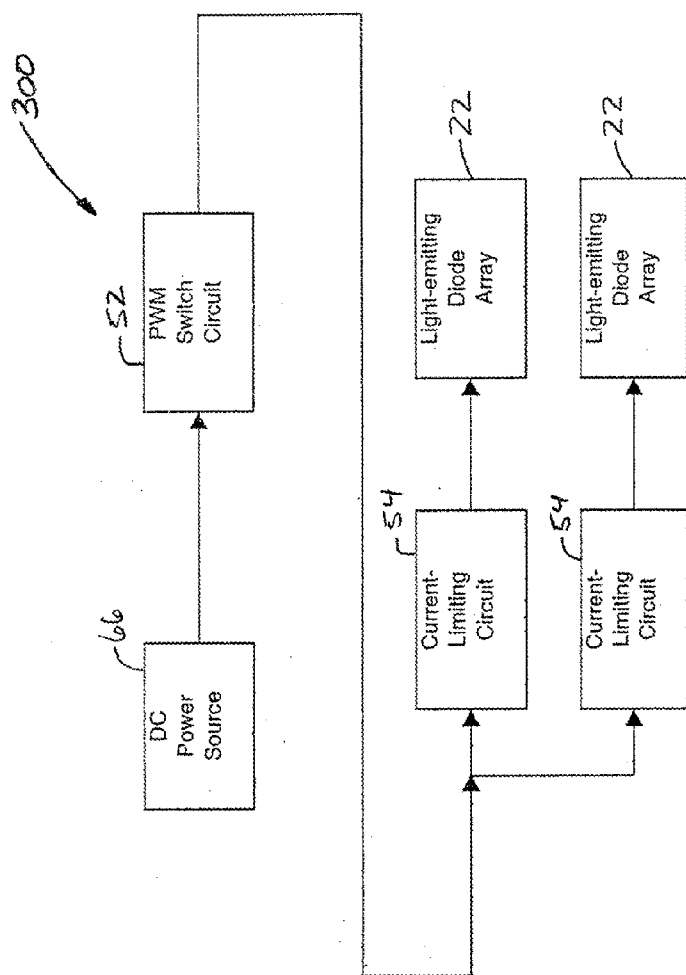

FIG. 8



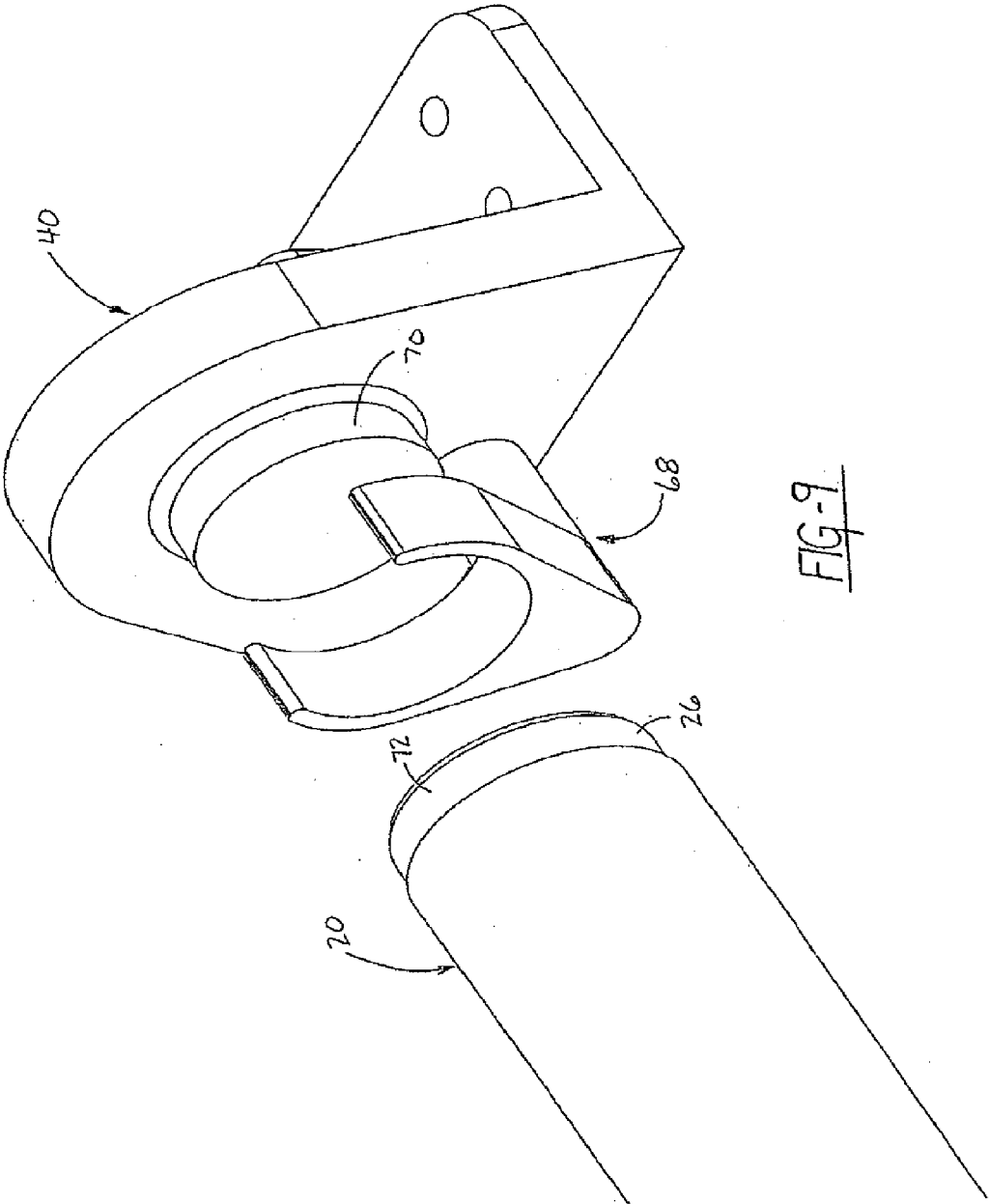

FIG-9

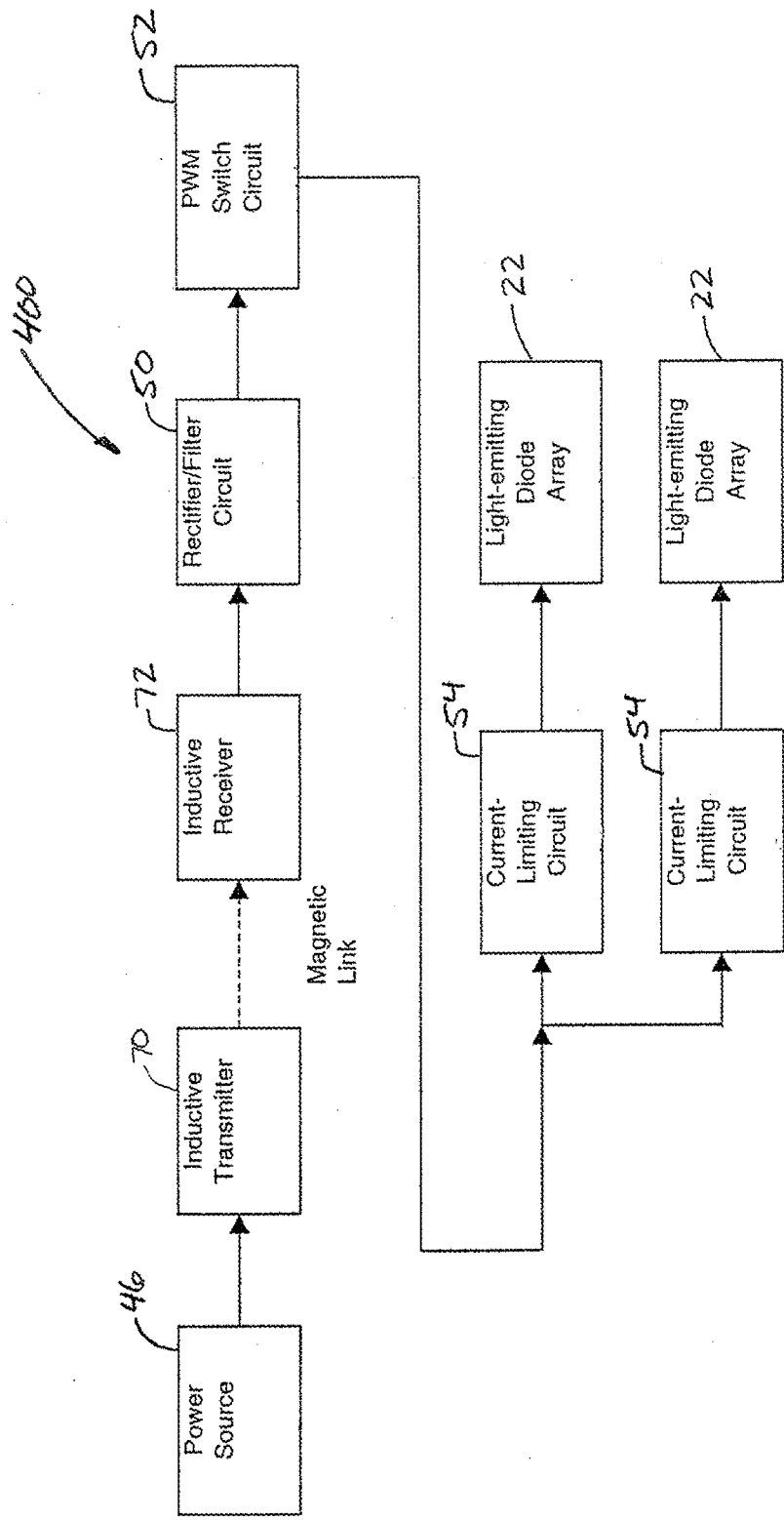

FIG. 10

**LIGHT TUBE AND POWER SUPPLY  
CIRCUIT**

**CROSS-REFERENCE TO RELATED  
APPLICATIONS**

[0001] This application is a continuation of U.S. patent application Ser. No. 15/187,456, filed Jun. 20, 2016, which is a continuation of U.S. patent application Ser. No. 14/865,325, filed Sep. 25, 2015 and issued as U.S. Pat. No. 9,416,923 on Aug. 16, 2016, which is a continuation of U.S. patent application Ser. No. 14/669,963, filed on Mar. 26, 2015 and issued as U.S. Pat. No. 9,222,626 on Dec. 29, 2015, which is a continuation of U.S. patent application Ser. No. 14/299,909, filed on Jun. 9, 2014 and issued as U.S. Pat. No. 9,006,990 on Apr. 14, 2015 and a continuation of U.S. patent application Ser. No. 14/299,915, filed Jun. 9, 2014 and issued as U.S. Pat. No. 9,006,993 on Apr. 14, 2015, which are continuations of U.S. Patent Application No. 13/777,331, filed Feb. 26, 2013 and issued as U.S. Pat. No. 8,866,396 on Oct. 21, 2014, which is a continuation of U.S. patent application Ser. No. 12/965,019, filed Dec. 10, 2010 and issued as U.S. Pat. No. 8,382,327 on Feb. 26, 2013, which is a continuation of U.S. patent application Ser. No. 11/085,744, filed Mar. 21, 2005 and issued as U.S. Pat. No. 8,247,985 on Aug. 21, 2012, which is a continuation of U.S. patent application Ser. No. 09/782,375, filed Feb. 12, 2001 and issued as U.S. Pat. No. 7,049,761 on May 23, 2006, which claims the benefit of U.S. Provisional Application No. 60/181,744 filed Feb. 11, 2000.

**FIELD OF THE INVENTION**

[0002] The present invention relates to a light tube illuminated by LEDs (light emitting diodes) which are packaged inside the light tube and powered by a power supply circuit.

**BACKGROUND OF THE INVENTION**

[0003] Conventional fluorescent lighting systems include fluorescent light tubes and ballasts. Such lighting systems are used in a variety of locations, such as buildings and transit buses, for a variety of lighting purposes, such as area lighting or backlighting. Although conventional fluorescent lighting systems have some advantages over known lighting options, such as incandescent lighting systems, conventional fluorescent light tubes and ballasts have several shortcomings. Conventional fluorescent light tubes have a short life expectancy, are prone to fail when subjected to excessive vibration, consume high amounts of power, require a high operating voltage, and include several electrical connections which reduce reliability. Conventional ballasts are highly prone to fail when subjected to excessive vibration. Accordingly, there is a desire to provide a light tube and power supply circuit which overcome the shortcomings of conventional fluorescent lighting systems. That is, there is a desire to provide a light tube and power supply circuit which have a long life expectancy, are resistant to vibration failure, consume low amounts of power, operate on a low voltage, and are highly reliable. It would also be desirable for such a light tube to mount within a conventional fluorescent light tube socket.

**SUMMARY OF THE INVENTION**

[0004] Embodiments of a replacement light tube for replacing a fluorescent light tube are disclosed herein. In one

embodiment, the replacement light tube for replacing a fluorescent light tube includes a bulb portion extending between a first end and a second end, the bulb portion comprising a support structure, a plurality of white light emitting diodes (LEDs) and an elongate light-transmissive cover. The support structure has a first surface extending between the first end and the second end. The plurality of LEDs are supported by the first surface and arranged between the first end and the second end. The elongate light-transmissive cover extends between the first end and the second end and over the first surface of the support structure. A first end cap and a second end cap are disposed on the first end and the second end, respectively, each configured to fit with a socket for a fluorescent light tube. A power supply circuit is configured to provide power to the plurality of LEDs. The plurality of LEDs are arranged to emit light through the elongate light-transmissive cover and at least a portion of the power supply circuit is packaged inside at least one of the end caps.

[0005] In another embodiment, the replacement light tube includes a bulb portion extending between a first end and a second end, the bulb portion comprising a support structure, a plurality of white light emitting diodes (LEDs) and an elongate light-transmissive cover. The support structure has a first surface extending between the first end and the second end. The plurality of LEDs are supported by the first surface and arranged between the first end and the second end, the LEDs being disposed along a base of a channel defined by the support structure. The elongate light-transmissive cover extends between the first end and the second end and over the first surface of the support structure. A first end cap and a second end cap are disposed on the first end and the second end, respectively, each configured to fit with a socket for a fluorescent light tube. A power supply circuit is configured to provide power to the plurality of LEDs, the power supply circuit comprising a rectifier configured to receive alternating current (AC) input from a ballast and to provide direct current (DC) output. The plurality of LEDs are arranged to emit light through the elongate light-transmissive cover and at least a portion of the power supply circuit is packaged inside at least one of the end caps.

[0006] These and other embodiments will be discussed in additional detail hereafter.

**BRIEF DESCRIPTION OF THE DRAWINGS**

[0007] The description herein makes reference to the accompanying drawings wherein like reference numerals refer to like parts throughout the several views, and wherein:

[0008] FIG. 1 is a line drawing showing a light tube, in perspective view, which in accordance with the present invention is illuminated by LEDs packaged inside the light tube;

[0009] FIG. 2 is a perspective view of the LEDs mounted on a circuit board;

[0010] FIG. 3 is a cross-sectional view of FIG. 2 taken along lines 3-3;

[0011] FIG. 4 is a fragmentary, perspective view of one embodiment of the present invention showing one end of the light tube disconnected from one end of a light tube socket;

[0012] FIG. 5 is an electrical block diagram of a first power supply circuit for supplying power to the light tube;

[0013] FIG. 6 is an electrical schematic of a switching power supply type current limiter;

**[0014]** FIG. 7 is an electrical block diagram of a second power supply circuit for supplying power to the light tube;

**[0015]** FIG. 8 is an electrical block diagram of a third power supply circuit for supplying power to the light tube;

**[0016]** FIG. 9 is a fragmentary, perspective view of another embodiment of the present invention showing one end of the light tube disconnected from one end of the light tube socket; and

**[0017]** FIG. 10 is an electrical block diagram of a fourth power supply circuit for supplying power to the light tube.

#### DETAILED DESCRIPTION

**[0018]** FIG. 1 is a line drawing showing a light tube 20 in perspective view. In accordance with the present invention, the light tube 20 is illuminated by LEDs 22 packaged inside the light tube 20. The light tube 20 includes a cylindrically shaped bulb portion 24 having a pair of end caps 26 and 28 disposed at opposite ends of the bulb portion. Preferably, the bulb portion 24 is made from a transparent or translucent material such as glass, plastic, or the like. As such, the bulb material may be either clear or frosted.

**[0019]** In a preferred embodiment of the present invention, the light tube 20 has the same dimensions and end caps 26 and 28 (e.g. electrical male bi-pin connectors, type G13) as a conventional fluorescent light tube. As such, the present invention can be mounted in a conventional fluorescent light tube socket.

**[0020]** The line drawing of FIG. 1 also reveals the internal components of the light tube 20. The light tube 20 further includes a circuit board 30 with the LEDs 22 mounted thereon. The circuit board 30 and LEDs 22 are enclosed inside the bulb portion 24 and the end caps 26 and 28.

**[0021]** FIG. 2 is a perspective view of the LEDs 22 mounted on the circuit board 30. A group of LEDs 22, as shown in FIG. 2, is commonly referred to as a bank or array of LEDs. Within the scope of the present invention, the light tube 20 may include one or more banks or arrays of LEDs 22 mounted on one or more circuit boards 30. In a preferred embodiment of the present invention, the LEDs 22 emit white light and, thus, are commonly referred to in the art as white LEDs. In FIGS. 1 and 2, the LEDs 22 are mounted to one surface 32 of the circuit board 30. In a preferred embodiment of the present invention, the LEDs 22 are arranged to emit or shine white light through only one side of the bulb portion 24, thus directing the white light to a predetermined point of use. This arrangement reduces light losses due to imperfect reflection in a conventional lighting fixture. In alternative embodiments of the present invention, LEDs 22 may also be mounted, in any combination, to the other surfaces 34, 36, and/or 38 of the circuit board 30.

**[0022]** FIG. 3 is a cross-sectional view of FIG. 2 taken along lines 3-3. To provide structural strength along the length of the light tube 20, the circuit board 30 is designed with a H-shaped cross-section. To produce a predetermined radiation pattern or dispersion of light from the light tube 20, each LED 22 is mounted at an angle relative to adjacent LEDs and/or the mounting surface 32. The total radiation pattern of light from the light tube 20 is effected by (1) the mounting angle of the LEDs 22 and (2) the radiation pattern of light from each LED. Currently, white LEDs having a viewing range between 6° and 45° are commercially available.

**[0023]** FIG. 4 is a fragmentary, perspective view of one embodiment of the present invention showing one end of the

light tube 20 disconnected from one end of a light tube socket 40. Similar to conventional fluorescent lighting systems and in this embodiment of the present invention, the light tube socket 40 includes a pair of electrical female connectors 42 and the light tube 20 includes a pair of mating electrical male connectors 44.

**[0024]** Within the scope of the present invention, the light tube 20 may be powered by one of four power supply circuits 100, 200, 300, and 400. A first power supply circuit includes a power source and a conventional fluorescent ballast. A second power supply circuit includes a power source and a rectifier/filter circuit. A third power supply circuit includes a DC power source and a PWM (Pulse Width Modulation) circuit. A fourth power supply circuit powers the light tube 20 inductively.

**[0025]** FIG. 5 is an electrical block diagram of a first power supply circuit 100 for supplying power to the light tube 20. The first power supply circuit 100 is particularly adapted to operate within an existing, conventional fluorescent lighting system. As such, the first power supply circuit 100 includes a conventional fluorescent light tube socket 40 having two electrical female connectors 42 disposed at opposite ends of the socket. Accordingly, a light tube 20 particularly adapted for use with the first power supply circuit 100 includes two end caps 26 and 28, each end cap having the form of an electrical male connector 44 which mates with a corresponding electrical female connector 42 in the socket 40.

**[0026]** The first power supply circuit 100 also includes a power source 46 and a conventional magnetic or electronic fluorescent ballast 48. The power source 46 supplies power to the conventional fluorescent ballast 48.

**[0027]** The first power supply circuit 100 further includes a rectifier/filter circuit 50, a PWM circuit 52, and one or more current-limiting circuits 54. The rectifier/filter circuit 50, the PWM circuit 52, and the one or more current-limiting circuits 54 of the first power supply circuit 100 are packaged inside one of the two end caps 26 or 28 of the light tube 20.

**[0028]** The rectifier/filter circuit 50 receives AC power from the ballast 48 and converts the AC power to DC power. The PWM circuit 52 receives the DC power from the rectifier/filter circuit 50 and pulse-width modulates the DC power to the one or more current-limiting circuits 54. In a preferred embodiment of the present invention, the PWM circuit 52 receives the DC power from the rectifier/filter circuit 50 and cyclically switches the DC power on and off to the one or more current-limiting circuits 54. The DC power is switched on and off by the PWM circuit 52 at a frequency which causes the white light emitted from the LEDs 22 to appear, when viewed with a "naked" human eye, to shine continuously. The PWM duty cycle can be adjusted or varied by control circuitry (not shown) to maintain the power consumption of the LEDs 22 at safe levels.

**[0029]** The DC power is modulated for several reasons. First, the DC power is modulated to adjust the brightness or intensity of the white light emitted from the LEDs 22 and, in turn, adjust the brightness or intensity of the white light emitted from the light tube 20. Optionally, the brightness or intensity of the white light emitted from the light tube 20 may be adjusted by a user. Second, the DC power is modulated to improve the illumination efficiency of the light tube 20 by capitalizing upon a phenomenon in which short pulses of light at high brightness or intensity to appear brighter than a continuous, lower brightness or intensity of

light having the same average power. Third, the DC power is modulated to regulate the intensity of light emitted from the light tube 20 to compensate for supply voltage fluctuations, ambient temperature changes, and other such factors that affect the intensity of white light emitted by the LEDs 22. Fourth, the DC power is modulated to raise the variations of the frequency of light above the nominal variation of 120 to 100 Hz thereby reducing illumination artifacts caused by low frequency light variations, including interactions with video screens. Fifth, the DC power may optionally be modulated to provide an alarm function wherein light from the light tube 20 cyclically flashes on and off

[0030] The one or more current-limiting circuits 54 receive the pulse-width modulated or switched DC power from the PWM circuit 52 and transmit a regulated amount of power to one or more arrays of LEDs 22. Each current-limiting circuit 54 powers a bank of one or more white LEDs 22. If a bank of LEDs 22 consists of more than one LED, the LEDs are electrically connected in series in an anode to cathode arrangement. If brightness or intensity variation between the LEDs 22 can be tolerated, the LEDs can be electrically connected in parallel.

[0031] The one or more current-limiting circuits 54 may include (1) a resistor, (2) a current-limiting semiconductor circuit, or (3) a switching power supply type current limiter.

[0032] FIG. 6 is an electrical schematic of a switching power supply type current limiter 56. The limiter 56 includes an inductor 58, electrically connected in series between the PWM circuit 52 and the array of LEDs 22, and a power diode 60, electrically connected between ground 62 and a PWM circuit/inductor node 64. The diode 60 is designed to begin conduction after the PWM circuit 52 is switched off. In this case, the value of the inductor 58 is adjusted in conjunction with the PWM duty cycle to provide the benefits described above. The switching power supply type current limiter 56 provides higher power efficiency than the other types of current-limiting circuits listed above.

[0033] FIG. 7 is an electrical block diagram of a second power supply circuit 200 for supplying power to the light tube 20. Similar to the first power supply circuit 100, the second power supply circuit 200 includes a conventional fluorescent light tube socket 40 having two electrical female connectors 42 disposed at opposite ends of the socket 40. Accordingly, a light tube 20 particularly adapted for use with the second power supply circuit 200 includes two end caps 26 and 28, each end cap having the form of an electrical male connector 44 which mates with a corresponding electrical female connector 42 in the socket 40.

[0034] In the second power supply circuit 200, the power source 46 supplies power directly to the rectifier/filter circuit 50. The rectifier/filter circuit 50, the PWM circuit 52, and the one or more current-limiting circuits 54 operate as described above to power the one or more arrays of LEDs 22. The rectifier/filter circuit 50, the PWM circuit 52, and the one or more current-limiting circuits 54 of the second power supply circuit 200 are preferably packaged inside the end caps 26 and 28 or the bulb portion 24 of the light tube 20 or inside the light tube socket 40.

[0035] FIG. 8 is an electrical block diagram of a third power supply circuit 300 for supplying power to the light tube 20. Similar to the first and second power supply circuits 100 and 200, the third power supply circuit 300 includes a conventional fluorescent light tube socket 40 having two electrical female connectors 42 disposed at opposite ends of

the socket 40. Accordingly, a light tube 20 particularly adapted for use with the third power supply circuit 300 includes two end caps 26 and 28, each end cap having the form of an electrical male connector 44 which mates with a corresponding electrical female connector 42 in the socket 40.

[0036] The third power supply circuit 300 includes a DC power source 66, such as a vehicle battery. In the third power supply circuit 300, the DC power source 66 supplies DC power directly to the PWM circuit 52. The PWM circuit 52 and the one or more current-limiting circuits 54 operate as described above to power the one or more arrays of LEDs 22. In the third power supply circuit 300, the PWM circuit 52 is preferably packaged in physical location typically occupied by the ballast of a conventional fluorescent lighting system while the one or more current-limiting circuits 54 and LEDs 22 are preferably packaged inside the light tube 20, in either one of the two end caps 26 or 28 or the bulb portion 24.

[0037] FIG. 9 is a fragmentary, perspective view of another embodiment of the present invention showing one end of the light tube 20 disconnected from one end of the light tube socket 40. In this embodiment of the present invention, the light tube socket 40 includes a pair of brackets 68 and the light tube 20 includes a pair of end caps 26 and 28 which mate with the brackets 68.

[0038] FIG. 10 is an electrical block diagram of a fourth power supply circuit 400 for supplying power to the light tube 20. Unlike the first, second, and third power supply circuits 100, 200, and 300 which are powered through direct electrical male and female connectors 44 and 42, the fourth power supply circuit 400 is powered inductively. As such, the fourth power supply circuit 400 includes a light tube socket 40 having two brackets 68 disposed at opposite ends of the socket 40. At least one bracket 68 includes an inductive transmitter 70. Accordingly, a light tube 20 particularly adapted for use with the fourth power supply circuit 400 has two end caps 26 and 28 with at least one end cap including an inductive receiver or antenna 72. When the light tube 20 is mounted in the light tube socket 40, the at least one inductive receiver 72 in the light tube 20 is disposed adjacent to the at least one inductive transmitter 70 in the light tube socket 40.

[0039] The fourth power supply circuit 400 includes the power source 46 which supplies power to the at least one inductive transmitter 70 in the light tube socket 40. The at least one transmitter 70 inductively supplies power to the at least one receiver 72 in one of the end caps 26 and/or 28 of the light tube 20. The at least one inductive receiver 72 supplies power to the rectifier/filter circuit 50. The rectifier/filter circuit 50, PWM circuit 52, and the one or more current-limiting circuits 54 operate as described above to power the one or more arrays of LEDs 22. In this manner, the light tube 20 is powered without direct electrical connection.

1-20. (canceled)

21. A method for providing a light tube for mounting within a conventional fluorescent light tube socket, the method comprising:

disposing a plurality of light emitting diodes within a tubular housing comprising a light transmissive cover; connecting a power supply circuit to the plurality of light emitting diodes, the power supply circuit being configured to receive power from a power source and

regulate an intensity of light emitted from the plurality of light emitting diodes during operation of the light tube;  
 disposing the power supply circuit within the light tube; and  
 disposing a pair of end caps at opposite ends of the tubular housing, each end cap configured to fit with the conventional fluorescent light tube socket.

**22.** The method of claim **21**, wherein the power supply circuit is configured to regulate the intensity of light emitted from the plurality of light emitting diodes to compensate for voltage fluctuations from the power source during operation of the light tube.

**23.** The method of claim **21**, wherein the power supply circuit is configured to regulate the intensity of light emitted from the plurality of light emitting diodes to compensate for ambient temperature changes during operation of the light tube.

**24.** The method of claim **21**, wherein the power supply circuit comprises a pulse width modulator configured to receive the power from the power source and provide regulated power to the light emitting diodes by pulse-width modulating the received power during operation of the light tube.

**25.** The method of claim **24**, wherein the power supply circuit comprises a current limiter having an inductive element electrically coupled between the pulse width modulator and at least some of the plurality of light emitting diodes, the current limiter configured to receive power from the pulse width modulator and to transmit power to the at least some of the plurality of light emitting diodes during operation of the light tube.

**26.** The method of claim **21**, wherein the power supply circuitry is configured to switch power to the plurality of light emitting diodes on and off at a frequency and to cause the light emitted from the plurality of light emitting diodes to appear, when viewed by a human eye, to shine continuously during operation of the light tube.

**27.** The method of claim **21**, wherein at least some components of the power supply circuits are disposed within at least one of the end caps.

**28.** The method of claim **21**, wherein the power supply circuit comprises a rectifier configured to receive alternating current (AC) input and to provide direct current (DC) output during operation of the light tube.

**29.** The method of claim **28**, wherein the rectifier is arranged to provide the DC output to a pulse width modulator during operation of the light tube.

**30.** The method of claim **21**, wherein each end cap comprises a bi-pin connector for connecting with the conventional fluorescent light tube socket.

**31.** The method of claim **30**, further comprising electrically connecting the power supply circuit to the bi-pin connector of at least one end cap.

**32.** The method of claim **21**, wherein disposing the plurality of light emitting diodes relative to the light transmissive cover comprises disposing the plurality of light emitting diodes on a rigid support structure and covering the light emitting diodes with the light transmissive cover of the tubular housing.

**33.** The method of claim **32**, wherein covering the rigid support structure comprises disposing the support structure within the tubular housing comprising the transmissive cover for the light emitting diodes.

**34.** The method of claim **33**, wherein the rigid support structure comprises spaced-apart sidewalls defining a channel and a planar portion having a first surface extending in the channel formed by the sidewalls, the light emitting diodes being disposed on the first surface.

**35.** The method of claim **34**, wherein at least a portion of the sidewalls contact an interior surface of the tubular housing when the support structure is disposed within the tubular housing.

**36.** The method of claim **34**, wherein, when disposed within the tubular housing, the support structure divides the tubular housing into a first space in which the plurality of light emitting diodes are housed and a second space defined by the planar portion, the sidewalls and the interior surface of the tubular housing.

**37.** The method of claim **34**, wherein the planar portion is integral with the sidewalls.

**38.** The method of claim **34**, wherein the sidewalls are generally perpendicular to the planar portion.

**39.** The method of claim **32**, wherein the support structure comprises a circuit board and the light emitting diodes are mounted on a surface of the circuit board.

**40.** The method of claim **21**, wherein the light emitting diodes are arranged along an axis extending between the end caps.

**41.** The method of claim **21**, wherein the light emitting diodes are white light emitting diodes.

**42.** The method of claim **21**, wherein the light transmissive cover is a tube formed from a transparent or translucent material.

**43.** The method of claim **21**, wherein the tubular housing is a cylindrical tube.

**44.** The method of claim **21**, wherein the light emitting diodes comprises a first light emitting diode and a second light emitting diode, the first light emitting diode being the light emitting diode closest to an end of the rigid support structure and the second light emitting diode being the next closest to the end of the rigid support structure, the first and second light emitting diodes being disposed such that a shortest distance between the first light emitting diode and the second light emitting diode is less than a shortest distance between the first light emitting diode and the end of the rigid support structure.

\* \* \* \* \*