



(19) **United States**

(12) **Patent Application Publication**
Simon et al.

(10) **Pub. No.: US 2011/0234076 A1**

(43) **Pub. Date: Sep. 29, 2011**

(54) **INSIDE-OUT LED BULB**

Publication Classification

(75) Inventors: **David L. Simon**, Grosse Pointe Woods, MI (US); **John Ivey**, Farmington Hills, MI (US)

(51) **Int. Cl.**
H01J 61/52 (2006.01)
H01S 4/00 (2006.01)
(52) **U.S. Cl.** **313/46; 29/592.1**

(73) Assignee: **ALTAIR ENGINEERING, INC.**, Troy, MI (US)

(57) **ABSTRACT**

(21) Appl. No.: **13/071,985**

An LED based light comprises a base, a light structure, a heat dissipating structure, and at least one LED. The light structure is adjacent to the base and extends along a longitudinal axis of the light. The light structure includes an inner surface and an outer surface and defines a cavity, and the heat dissipating structure extends into the cavity. At least one LED is mounted in thermally conductive relation to the heat dissipating structure. In one version, the light structure is an annular flange, and an organic LED is mounted to the outer surface. In another version, the light structure is a light pipe configured to distribute a light produced by the at least one LED in a predetermined light distribution.

(22) Filed: **Mar. 25, 2011**

Related U.S. Application Data

(60) Provisional application No. 61/317,871, filed on Mar. 26, 2010.

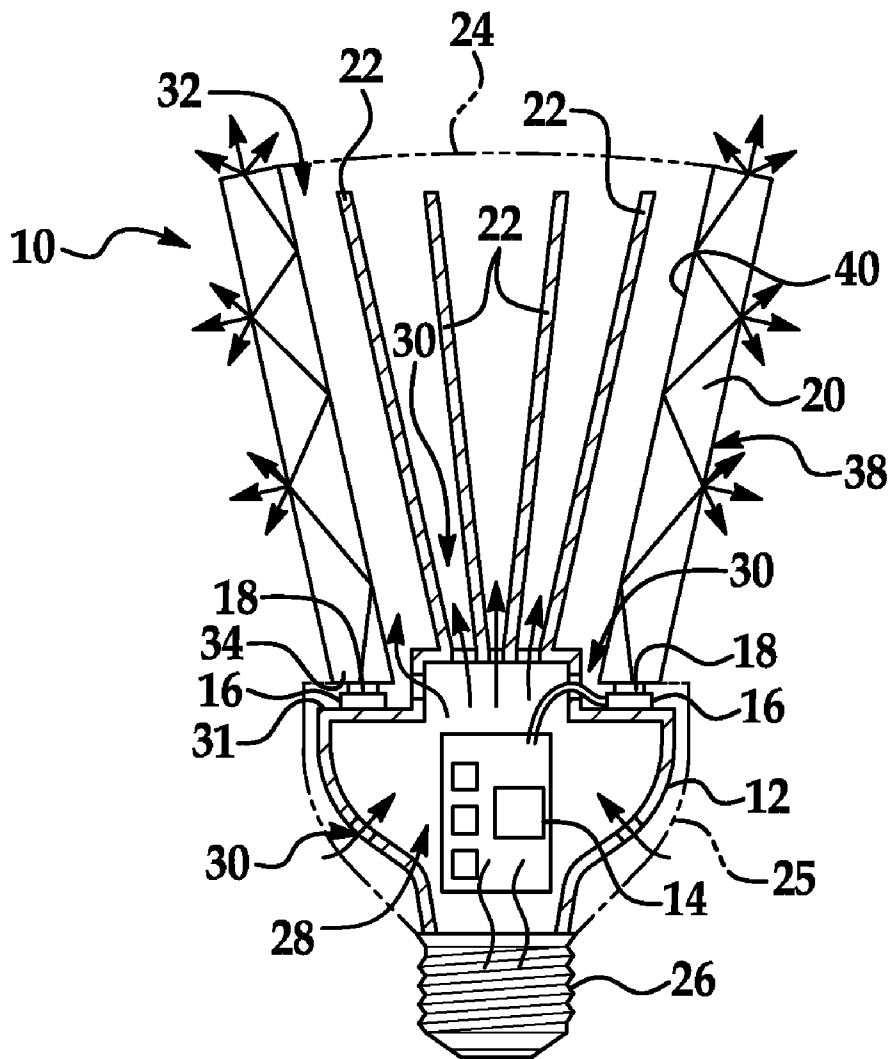

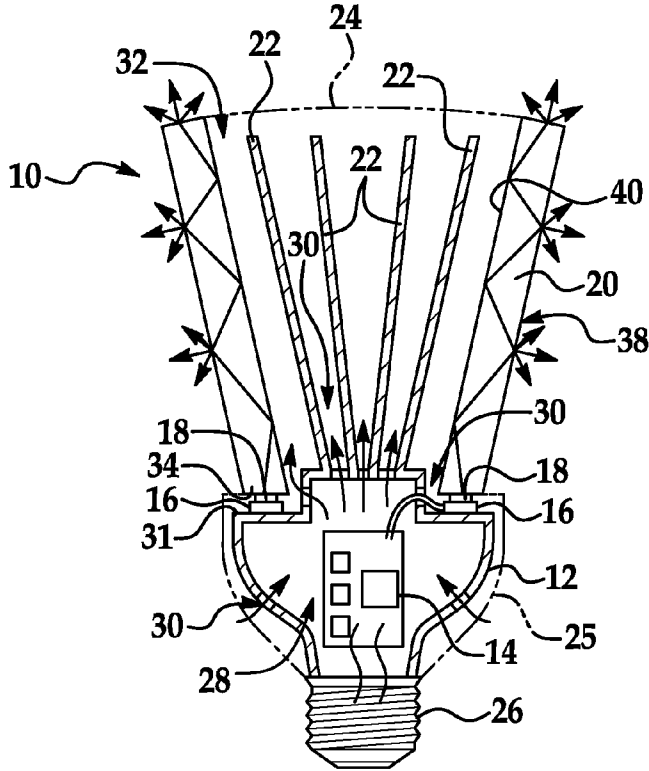

FIG. 1

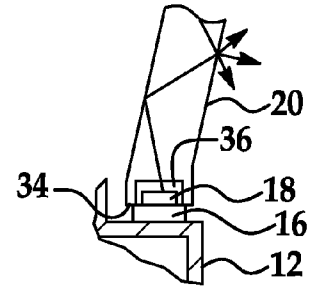

FIG. 2

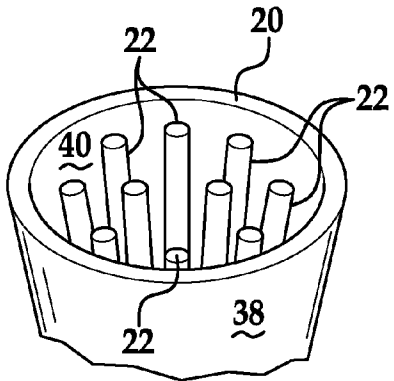

FIG. 3

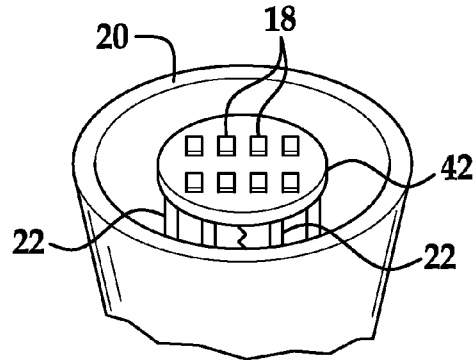

FIG. 4

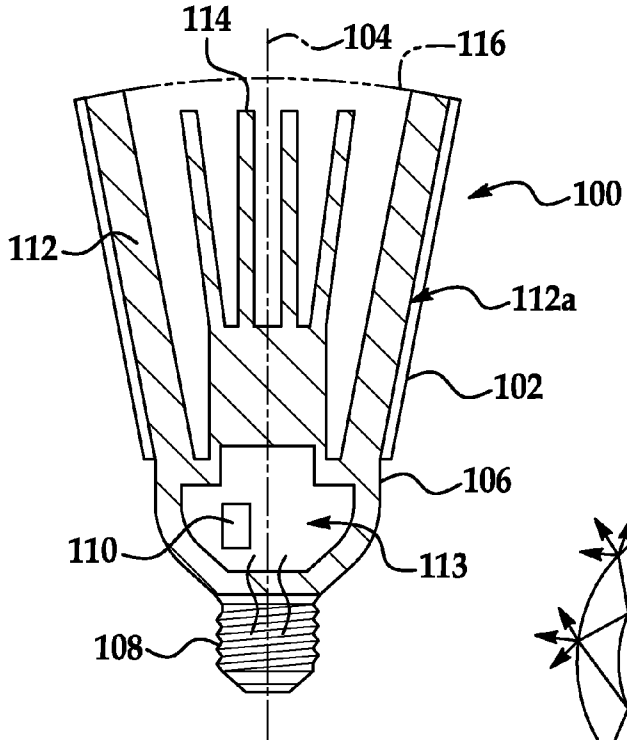

FIG. 5

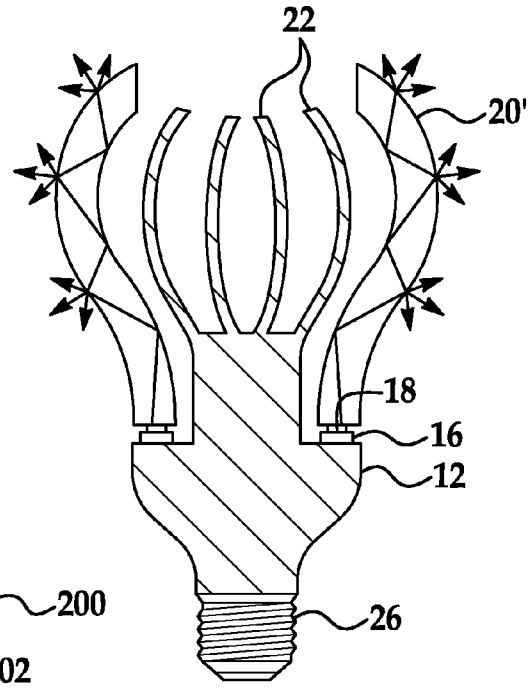

FIG. 6

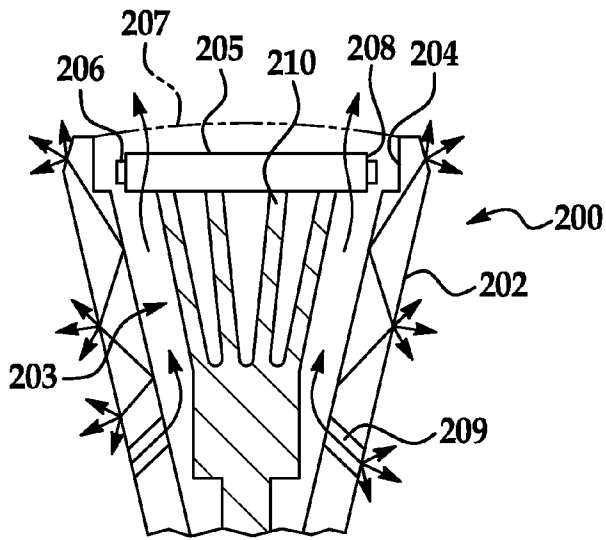

FIG. 7

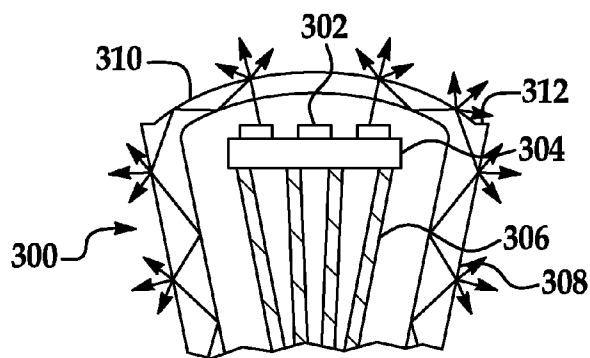

FIG. 8

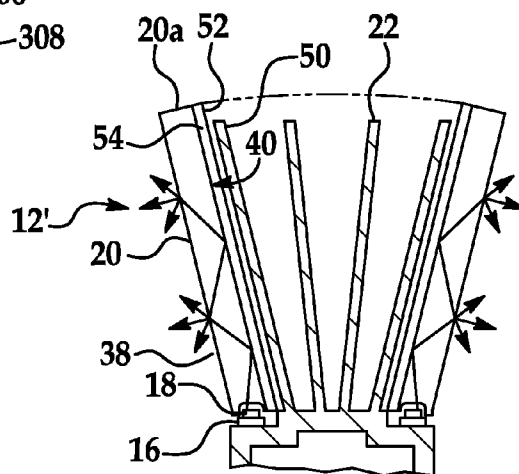

FIG. 9

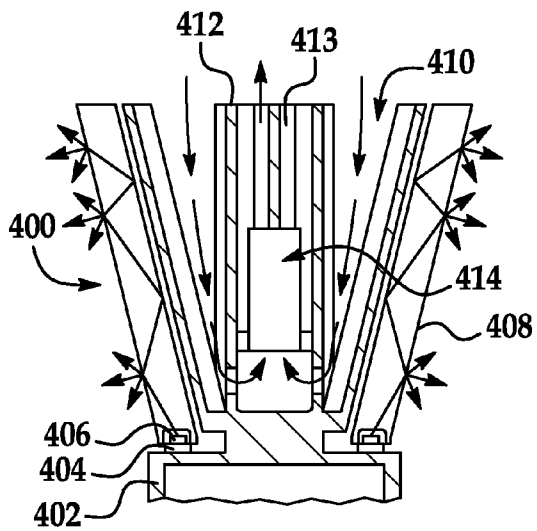

FIG. 10

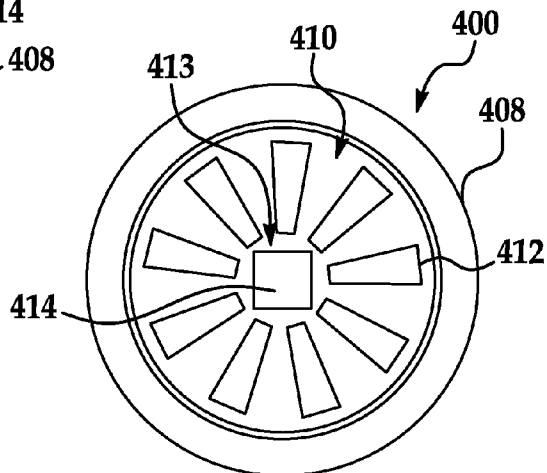

FIG. 11

INSIDE-OUT LED BULB

CROSS REFERENCE TO RELATED APPLICATION

[0001] This application claims priority to U.S. Provisional Patent Application No. 61/317,871, filed Mar. 26, 2010, which is incorporated herein by reference in its entirety.

TECHNICAL FIELD

[0002] The invention relates to a light emitting diode (LED) based light, for example, an LED-based light bulb usable in an Edison-type fixture in place of a conventional incandescent bulb.

BACKGROUND

[0003] Incandescent light bulbs are commonly used in many environments, such as households, commercial buildings, and advertisement lighting, and in many types of fixtures, such as desk lamps and overhead fixtures. Incandescent bulbs can each have a threaded electrical connector for use in Edison-type fixtures, though incandescent bulbs can include other types of electrical connectors such as a bayonet connector or pin connector. Incandescent light bulbs generally consume large amounts of energy and have short life-spans. Indeed, many countries have begun phasing out or plan to phase out the use of incandescent light bulbs entirely.

[0004] Compact fluorescent light bulbs (CFLs) are gaining popularity as replacements for incandescent light bulbs. CFLs are typically much more energy efficient than incandescent light bulbs, and CFLs typically have much longer life-spans than incandescent light bulbs. However, CFLs contain mercury, a toxic chemical, which makes disposal of CFLs difficult. Additionally, CFLs require a momentary start-up period before producing light, and many consumers do not find CFLs to produce light of similar quality to incandescent bulbs. Further, CFLs are often larger than incandescent lights of similar luminosity, and some consumers find CFLs unsightly when not lit.

[0005] Known LED-based light bulbs have been developed as an alternative to both incandescent light bulbs and CFLs. Known LED light bulbs typically each include a base that functions as a heat sink and has an electrical connector at one end, a group of LEDs attached to the base, and a bulb. The bulb often has a semi-circular shape with its widest portion attached to the base such that the bulb protects the LEDs.

SUMMARY

[0006] Known LED-based light bulbs suffer from multiple drawbacks. A base of a typical known LED-based light bulb is unable to dissipate a large amount of heat, which in turn limits the amount of power that can be supplied to LEDs in the typical known LED-based light bulb without a high risk of the LEDs overheating. As a result of the power supplied to the LEDs being limited, the typical known LED-based light bulb has a limited luminosity and cannot provide as much light as an incandescent light bulb that the LED-based light bulb is intended to replace.

[0007] In an effort to increase the luminosity of known LED-based light bulbs, some known LED-based light bulbs include over-sized bases having large surface areas. The large surface areas of the over-sized bases are intended to allow the bases to dissipate sufficient amounts of heat such that the LEDs of each known LED-based light can be provided with

enough power to produce in the aggregate as much luminosity as the respective incandescent bulbs that the LED-based light bulbs are intended to replace. However, the total size of one of the LED-based lights is often limited, such as due to a fixture size constraint. For example, a desk lamp may only be able to accept a bulb having a three to four inch diameter, in which case the over-sized base of an LED-based light should not exceed three to four inches in diameter. Thus, the size of the over-sized base for the known LED-based light bulb is constrained, and heat dissipation remains problematic.

[0008] Further, the use of over-sized bases in some known LED-based light bulbs detracts from the distributions of light emanating from the bulbs. That is, for a typical known LED-based light bulb having one of the over-sized bases, the over-sized base has a diameter as large as or larger than a maximum diameter of the bulb of the known LED-based light bulb. As a result of its small bulb diameter to base diameter ratio, the base blocks light that has been reflected by the bulb and would otherwise travel in a direction toward an electrical connector at an end of the base. The typical known LED-based light bulb thus does not direct much light in a direction toward the electrical connector. For example, when the typical known LED-based light bulb having an over-sized base is installed in a lamp or other fixture in which the bulb is oriented with its base below its bulb, very little light is directed downward. Thus, the use of over-sized bases can also prevent known LED-based lights from closely replicating the light distribution of incandescent bulbs.

[0009] In addition to using over-sized bases, other attempts have been made to increase the ability of known LED-based light bulbs to dissipate heat. For example, bases of some known LED-based light bulbs include motorized fans for increasing the amounts of airflow experienced by the bases. However, known LED-based light bulbs including fans often produce audible noise and are expensive to produce. As another example, bases of known LED-based lights have been provided with axially extending ribs in an attempt to increase the surface areas of the bases without too greatly increasing the diameters of the bases. However, such ribs often have the effect of acting as a barrier to air flow and, as a result, tend to stall air flow relative to the base. As a result, bases with ribs typically do not provide a sufficient amount of heat dissipation. As yet another example, fluid fill LED-based lights have been introduced, with the fluid intended to efficiently transfer heat from LEDs to outside shells of the lamps. However, these lamps are at risk for leaking or spilling their fluid, and allowance must be made for thermal expansion of the fluid, thereby reducing the heat-transferring ability of the lamps.

[0010] Examples of “inside-out” LED-based bulbs described herein can have advantages over known LED-based light bulbs. For example, an example of an inside-out LED-based bulb can include a base. The base can include a physical and/or electrical connector on one of its ends, and the base can define a compartment that can contain electronics such as a power converter and/or any other electronics in electric communication with the electrical connector. One or more LEDs can be mounted on an opposing end of the base and if more than one LED is included the LEDs can be mounted on an annular circuit board that is in electrical communication with the electronics. An annular light pipe can be positioned over the LEDs such that light produced by the LEDs enters the light pipe. High-surface area heat dissipating structures, such as fins or pins, can extend from the base

through a cavity defined by the annular light pipe. A thermal shroud can be positioned over distal ends of the heat dissipating structures to protect against, as an example, inadvertent contact of a hand with one or more of the heat dissipating structures. An additional group of LEDs can optionally be mounted on a distal end of the heat dissipating structures interior of the thermal shroud. Other inside-out LED-based bulb configurations are also described herein.

[0011] In operation, the inside-out LED-based bulb can be engaged with a conventional fixture designed to receive, for example, an incandescent bulb. When powered, the electronics of the LED-based bulb can convert power received from the fixture via the electrical connector to a type of power suitable for the LEDs, and that power can be transferred to the LEDs via the circuit board. As such, the LEDs can produce light, and that light can enter the light pipe, which can in turn distribute the light in a manner closely replicating an incandescent bulb. Moreover, heat produced by the LEDs can pass to the base via the circuit board, and from the base to the heat dissipating structures. The surface area of the heat dissipating structures can be large enough to dissipate a sufficient amount of heat to allow the LEDs to use an amount of power sufficient for the LEDs to replicate an incandescent bulb. Additionally, as a result of the location of the heat dissipating structures—inside the cavity defined by the annular light pipe—the structures do not interfere with the distribution of light. Thus, inside-out LED-based lights as described herein can each produce a sufficient amount of light to replicate incandescent bulbs without overheating because of their heat dissipating ability, and the lights can produce that light in a distribution closely replicating an incandescent bulb because a large light blocking base acting as a heat sink can be avoided.

[0012] One aspect of an “inside-out” LED based light comprises a base having a first end and a second end and a light structure adjacent to the base and extending along a longitudinal axis of the light. The light structure includes an inner surface and an outer surface and defines a cavity. A heat dissipating structure extends into the cavity and at least one LED is mounted in thermally conductive relation to the heat dissipating structure.

[0013] In another aspect of an LED based light for replacing a conventional incandescent light bulb, the LED based light comprises a connector configured to provide a physical connection to a conventional incandescent light fixture, at least one LED and a light pipe having an inner surface and an outer surface and extending along a longitudinal axis of the light to define a cavity radially inward of the inner surface. The light pipe is optically configured to receive a light emitted by the at least one LED and to distribute substantially all of the received light radially outward from the light pipe in a predetermined light distribution. A heat dissipating structure is in thermally conductive relation to the at least one LED and extending into the cavity.

[0014] Also disclosed are methods of making an LED based light. One method comprises providing a base having a first end and a second end, mounting a light structure having an inner surface and an outer surface and defining a cavity adjacent to the base so that the light structure extends along a longitudinal axis of the light, providing a heat dissipating structure within the cavity and mounting at least one LED in thermally conductive relation to the heat dissipating structure.

BRIEF DESCRIPTION OF THE DRAWINGS

[0015] The description herein makes reference to the accompanying drawings wherein like reference numerals refer to like parts throughout the several views, and wherein:

[0016] FIG. 1 is a cross sectional view of an example of an inside-out LED-based bulb taken along a longitudinal axis of the LED-based bulb;

[0017] FIG. 2 is a blown-up view of a region of FIG. 1 including an LED and a proximal end of a light pipe;

[0018] FIG. 3 is a partial perspective view of the bulb of FIG. 1;

[0019] FIG. 4 is a partial perspective view of another example of an inside-out LED-based bulb;

[0020] FIG. 5 is a cross sectional view of a yet another example of an inside-out LED-based bulb taken along a longitudinal axis of the LED-based bulb;

[0021] FIG. 6 is a cross sectional view of a still yet another example of an inside-out LED-based bulb taken along a longitudinal axis of the LED-based bulb;

[0022] FIG. 7 is a cross sectional view of a portion of a further example of an inside-out LED-based bulb taken along a longitudinal axis of the LED-based bulb;

[0023] FIG. 8 is a cross sectional view of a portion of still a further example of an inside-out LED-based bulb taken along a longitudinal axis of the LED-based bulb;

[0024] FIG. 9 is a cross sectional view of a portion of yet a further example of an inside-out LED-based bulb taken along a longitudinal axis of the LED-based bulb;

[0025] FIG. 10 is a cross sectional view of a portion of an additional example of an inside-out LED-based bulb taken along a longitudinal axis of the LED-based bulb; and

[0026] FIG. 11 is a top plan view of the bulb of FIG. 10.

DESCRIPTION

[0027] Examples of inside-out LED-based bulbs are discussed herein with reference to FIGS. 1-11. The bulbs are referred to as being “inside-out” because the bulbs can include heat dissipating structures located radially inward of a light source, such as a light pipe, relative to longitudinal axes of the bulbs. (An example of a longitudinal axis **104** is shown in FIG. 5, and the term radial refers to a direction orthogonal to a longitudinal axis unless otherwise indicated.) A first example of an inside-out LED-based bulb **10** in FIG. 1 is configured to replace a conventional incandescent light bulb in a conventional fixture, such as an Edison-type fixture. Alternatively, the bulb **10** can be configured to replace another type of bulb. The bulb **10** can include a base **12** that houses electronics **14**, a circuit board **16**, a plurality of LEDs **18**, a light pipe **20**, heat dissipating structures **22** and thermal shrouds **24** and **25**.

[0028] One end of the base **12** can include an electrical connector **26**. The electrical connector **26** as illustrated is of the Edison-type, although the base can alternatively include another type of electrical connector **26** such a bi-pin or bayonet type connector. The type of connector **26** can depend on the type of fixture that the bulb **10** is designed to be engaged with. In addition to providing an electrical connection between the bulb **10** and the fixture, the connector **26** can also serve to physically connect the bulb **10** to the fixture. For example, by screwing the connector **26** into engagement with an Edison-type fixture, the bulb **10** is both physically and electrically connected to the fixture. Additionally, the connector **26** can be in electrical communication with the electronics **14**. For example, electrically conductive wires can link the connector **26** and electronics **14**. The connector **26** can be snap-fit, adhered, or otherwise fixed to a remainder of the base **12**. The base **12** can be constructed from a highly thermally conductive material, such as aluminum, another metal, or a

highly thermally conductive polymer. The base **12** can be painted, powder-coated, or anodized to improve its thermal emissivity. For example, a thermally conductive, high emissivity paint (e.g., a paint having an emissivity of greater than 0.5) can be applied to at least a portion of an exterior of the base **12**.

[0029] The base **12** can be hollow so as to define a compartment **28** large enough to receive electronics **14**. The electronics **14** can include, as an example, power conversion electronics (e.g., a rectifier, a filtering capacitor, and/or DC to DC conversion circuitry) for modifying power receive from the connector **26** to power suitable for transmission to the circuit board **16**. By forming the connector **26** separately from the remainder of the base **12** as mentioned above, the base **12** not including the connector **26** can define an opening for installation of the electronics **14**. The opening in the base **12** can then be sealed when the connector **26** is fixed to the base **12**.

[0030] The base **12** can define various apertures **30**. The apertures **30** can be at one or more of a variety of locations, such as along the base **12** between connector **26** and the circuit board **16**, adjacent and radially inward of the circuit board **16**, and adjacent the heat dissipating structures **22**. Each aperture **30** can provide a path of airflow between the compartment **28** and an ambient environment external the base **12**. As a result, the apertures **30** can allow airflow between the compartment **28** and the ambient environment external the base **12**, thereby facilitating heat transfer from the base **12** and electronics **14** to the ambient environment. Additionally, an electrical connection between the electronics **14** and circuit board **16** can pass through one or more of the apertures **30**.

[0031] The base **12** can additionally define an annular platform **31**. The platform **31** can be generally planar. The circuit board **16** can be annular and can be mounted on the platform **31**. For example, the circuit board **16** can be attached to the platform **31** using thermally conductive tape or in another manner, such as using an adhesive or a snap-fit connection. The circuit board **16** can be electrically connected to the electronics **14**, such as by way of electrically conductive wires extending through one or more of the apertures **30** and linking the circuit board **16** to the electronics **14**.

[0032] The circuit board **16** can be an annular printed circuit board. Additionally, the circuit board **16** can be formed of multiple discrete circuit board sections, which can be electrically connected to one another using, for example, bridge connectors. For example, the circuit board **16** can be formed of multiple rectangular circuit boards arranged about the platform **31**. Also, other types of circuit boards may be used, such as a metal core circuit board. Or, instead of a circuit board **16**, other types of electrical connections (e.g., wires) can be used to electrically connect the LEDs **18** to each other and/or the electronics **14**.

[0033] The LEDs **18** can be mounted on the circuit board **16** and in electrical communication therewith. As such, the LEDs **18** can be arranged in an annular configuration with the heat dissipating structures **22** extending from the base **12** radially inward of the LEDs **18**. The LEDs **18** can be spaced at even intervals around the platform **31**, although the LEDs **18** can alternatively be arranged in another fashion, such as in a pattern of two or more circles having different diameters. The LEDs **18** can be surface-mount devices of a type available from Nichia, though other types of LEDs can alternatively be used. For example, although surface-mounted LEDs **18** are

shown, one or more organic LEDs can be used in place of or in addition thereto. Each LED **18** can include a single diode or multiple diodes, such as a package of diodes producing light that appears to an ordinary observer as coming from a single source. The LEDs **18** can be mounted on and electrically connected to the circuit board **16** using, for example, solder or another type of connection. The LEDs **18** can emit white light. However, LEDs that emit blue light, ultra-violet light or other wavelengths of light can be used in place of white light emitting LEDs **18**.

[0034] The number and power level of the LEDs **18** can be selected such that the bulb **10** can produce a similar amount of luminosity as a conventional incandescent bulb that the bulb **10** is intended to be a substitute for. For example, if the bulb **10** is intended as a substitute for a 60 W incandescent bulb, the LEDs **18** in the aggregate can require 8-15 W of power, although this power level may change as LED technology improves. If the bulb **10** is intended to replicate another type of bulb, the LEDs **18** can output a different amount of light. The LEDs **18** can be oriented to face parallel to the longitudinal axis of the bulb **10**, although the LEDs **18** can alternatively be oriented at an angle to the illustrated position.

[0035] The light pipe **20** can have a generally annular shape, and the light pipe **20** can define a cavity **32** radially inward of the light pipe **20**. The light pipe **20** can be positioned to receive light produced by the LEDs **18**. For example, the light pipe **20** can have an annular-shaped proximal end **34** that defines an annular cutaway **36** sized to receive the LEDs **18** as shown in FIG. 2. The cutaway **36** can be continuous and annular shaped, or can have an alternative shape such as a plurality of circumferentially spaced discrete indentations spaced in accordance with spacing of the LEDs **18**. The light pipe **20** can be positioned such that the LEDs **16** are received in the cutaway **36**. Alternatively, the proximal end **34** can be planar and positioned against or slightly above the LEDs **18** with reference to the orientation shown in FIG. 1. As another alternative, if the light pipe **20** is hollow, the proximal end **34** can be an opening between radially spaced sidewalls of the light pipe **20**. The light pipe **20** can be attached to the base **12** and/or the circuit board **14**. For example, the light pipe **20** can be adhered or snap-fit to the base **12**. Moreover, the light pipe **20** can be attached to the base radially outward of the circuit board **14** such that the base **12** and light pipe **20** effectively seal off the circuit board **14**.

[0036] The light pipe **20** can be optically configured to direct light produced by the LEDs **16** that enters the light pipe **20** in a distribution that appears to an ordinary observer to replicate the incandescent bulb which the bulb **10** is a substitute for, although the light pipe **20** can produce an alternative distribution of light depending on its configuration. Experimentation, a computational model or other means can be used to determine the specific shape of the light pipe **20** in order to achieve a certain light distribution. While the light pipe **20** shown in FIG. 1 has a conical shape including a linear outer radial surface **38** and a linear inner radial surface **40**, both of which extend radially outward as the light pipe **20** extends away from the base **12**, the light pipe **20** can have other shapes. For example, FIG. 6 shows a light pipe **20'** having a bulbous profile similar to a conventional incandescent bulb. The bulbous profile of the light pipe **20'** can have a more familiar appearance for consumers. Additionally, the light pipe **20'** can provide a different light distribution than the light pipe **20**, with the light pipe **20'** distributing a greater amount of light in a longitudinal direction.

[0037] The shape of the light pipe 20 can be designed such that, as an example, the inner radial surface 40 causes total internal reflection of most light that contacts the surface 40, thereby reducing or eliminating the amount of light that enters the cavity 32. In addition to shaping the light pipe 20 to achieve a certain light distribution, other means for achieving a certain light distribution can also be used as discussed below with reference to FIG. 9. The light pipe 20 can be hollow or solid between surfaces 38 and 40.

[0038] The heat dissipating structures 22 can extend away from the base 12 within the cavity 32 defined by the light pipe 20, and the heat dissipating structures 22 can be in thermal communication with the base 12, including the platform 31. As such, the heat dissipating structures 22 can be in thermal communication with the LEDs 18 via the circuit board 16. The structures 22 can be made from highly thermally conductive material, such as aluminum, another metal, or a highly thermally conductive plastic. The shape of the structures 22 can provide a high surface area to volume ratio, or otherwise be designed to aid heat dissipation. For example, the structures 22 can be pins as shown in FIG. 3, fins, concentric conical shapes of varying diameters, a lattice-type structure, or any other heat-sink type shape. The heat dissipating structures 22 can be integrally formed with the base 12 (e.g., via machining or casting), or formed separately and attached thereto.

[0039] The shrouds 24 and 25 can protect against accidental contact with the bulb 10. For example, the shrouds 24 and 25 can be formed of thermally insulating materials (e.g., plastic) and spaced from the base 12 and heat dissipating structures 22, respectively, so as to remain at a relatively cool temperature regardless of the temperatures of the base 12 and/or the heat dissipating structures 22. The shroud 24 can extend over a distal end of the cavity 32 and can be attached to the light pipe 20. For example, the shroud 24 can be attached to the inner radial surface 40 of the light pipe 20 adjacent the distal end of the light pipe 20 opposite the platform 31 so as not to block any light passing through the distal end of the light pipe 20. The shroud 24 can be adhered to the light pipe 20 or attached in another manner (e.g., the shroud 24 can be integrally formed with the light pipe 20). The shroud 24 can include apertures to facilitate airflow between the cavity 32 and the ambient environment, or the shroud can be solid 24. The shroud 24 can protect against inadvertent contact with the heat dissipating structures 22, which may become hot during usage of the bulb 10. Similarly, the shroud 25 can cover the base 12, and can also cover a junction between the light pipe 20 and base 12. The shroud 25 can protect against inadvertent contact with the base 12.

[0040] In operation, the bulb 10 can be installed in a conventional fixture, such as an Edison-type fixture in a lamp, ceiling or other location. Electricity can be supplied to the bulb 10 via the connector 26, and the electricity can pass to the electronics 14. The electronics 14 can convert the electricity to a form acceptable for the LEDs 18, and the converted electricity can pass to the circuit board 16 and, in turn, the LEDs 18. In response, the LEDs 18 can produce light. The light can enter the light pipe 20, which can distribute the light to replicate a conventional incandescent bulb or some other predetermined pattern. Heat produced by the LEDs 18 during operation can pass through the circuit board 16 to the base 12, and from the base 12 to the ambient environment and to the heat dissipating structures 22. The heat dissipating structures 22 can dissipate heat into the cavity 32. Heat in the cavity 32

can reach the ambient environment by dissipating across or through apertures in the shroud 24. As a result of the heat dissipation abilities of the base 12 and its heat dissipating structures 22, the LEDs 18 can produce a sufficient amount of light to replace an incandescent bulb or another type of light without overheating. Further, the light pipe 20 can distribute that light in a manner replicating the even distribution of the incandescent bulb, although other distributions are also possible.

[0041] In another example shown in FIG. 4, the LED-based bulb 10 can include a second circuit board 42 atop the heat dissipating structures 22 and having LEDs 18 mounted thereon. The second circuit board 42 and its LEDs 18 can supplement or act as a substitute for light passing out the distal end of the light pipe 20. The second circuit board 42 can be attached to the heat dissipating structures 22 using, as an example, thermally conductive tape or an adhesive, and the board 42 can be electrically connected to the electronics 14 or the circuit board 16 using electrically conductive wires that extend through the cavity 32. If the shroud 24 is used, the shroud 24 can be formed of a light transmitting material.

[0042] Another example of an inside-out LED-based bulb 100 shown in FIG. 5 includes organic LEDs (also known as OLEDs) 102. The bulb 100 can include a base 106 having an electrical connector 108 and housing electronics 110 in a cavity 113 similar to as described above in respect of the base 12, its connector 26 and electronics 14. The OLEDs 102 can be in electrical communication with the electronics 110 for receiving power received by the connector 108. The base 106 can have a conical flange 112, and the OLEDs 102 can be attached to an outer radial surface 112a the conical flange 112 such that the OLEDs 102 extend circumferentially about the flange 112. The OLEDs 102 can be attached to the flange 112 using, as example, adhesive or thermally conductive tape. The base 106 can additionally include heat dissipating structures 114, such as pins, fins, a lattice-type structure, a series of concentric conical extensions, or other high surface area to volume shapes, radially inward of the OLEDs 102 and the flange 112. The flange 112 and structures 114 can be in thermal communication such that the structures 114 can aid in dissipating heat transferred from the OLEDs 102 to the flange 112. A thermal shroud 116 can extend over the flange 112 to cover the flange and structures 114, and the shroud 116 can have the same configuration as the shroud 24 discussed above with respect to FIG. 1.

[0043] Note that the OLEDs 102 need not extend continuously about the entire surface of the exterior surface 112a of the flange 112, and can instead, as an example, be circumferentially or longitudinally spaced from one another. Alternatively, a single OLED 102 can be wrapped around the flange 112. Additionally, another OLED or LED can be attached to a distal end of the heat dissipating the flange 112 and/or structures 114 for producing light along the axis 104. Also, the flange 112 can be formed of multiple discrete, circumferentially spaced flange portions or can have an alternative structure for supporting OLEDs 102 and receiving heat therefrom.

[0044] In operation, as a result of being attached to the flange 112 the OLEDs 102 are in thermal communication with the flange 112 and heat produced by the OLEDs 102 during operation can be communicated to the base 106. The OLEDs 102 can produce light radially outward from the axis 104 in a distribution replicating an incandescent bulb. Further, since heat can be effectively dissipated from the OLEDs

102 by the flange **112** and heat dissipating structures **114**, the LEDs **102** can operate at a sufficiently high power to produce a similar amount of light as an incandescent bulb without overheating.

[0045] FIG. 7 shows another example of an inside-out of an inside-out LED-based bulb **200**. The bulb **200** includes a conical light pipe **202** having a light receiving portion **204** along a radial interior of a distal end of the light pipe **202** (relative to a base not shown in FIG. 7). Alternatively, the light receiving portion **204** can have a different location, such as spaced more toward a proximal end of the light pipe **202**. The light receiving portion **204** can extend circumferentially about the entire light pipe **202** or can be comprised of a series of light receiving portions. Heat dissipating structures **210**, such as pins, fins, or a lattice structure, can extend from a base toward a distal end of the light pipe **202** within a cavity **203** defined by the light pipe **202**. A disk **205** of thermally conductive material can be positioned atop the heat dissipating structures **210** for thermal communication therewith. LEDs **206** can be positioned on an outer radial side **208** of disk **205**. For example, the LEDs **206** can be mounted on an annular circuit board attached to the disk **205** and in electrical communication with a connector of the bulb **200**. The LEDs **206** can face the light receiving portion **204** such that light produced by the LEDs **206** enters the light pipe **202** and can be distributed to replicate the distribution of light provided by, for example, an incandescent bulb. Alternatively, if no disk **205** is included, the LEDs **206** can be attached to distal ends of the heat dissipating structures **210**. A thermally protective shroud **207** can span the cavity **203** to protect against, for example, in advertent contact with the disk **205** and/or LEDs **206**, and the shroud **207** can include apertures for allowing air flow between the cavity **203** and ambient environment external the bulb **200**.

[0046] In operation, the LEDs **206** can receive power from a fixture via any electronics included in a base of the bulb **200** and any circuit board on which the LEDs **206** are mounted. The LEDs **206** can produce light in response to receiving power, and that light can enter the light pipe **202**. The light pipe **202** can distribute the light longitudinally and radially to replicate, for example, a conventional incandescent bulb. Heat produced by the LEDs **206** during operation can be communicated to the disk **205**, from the disk **205** to the heat dissipating structures **210**, and from the heat dissipating structures **210** to air in the cavity **203**. The air in the cavity **203** can circulate with air in the ambient environment via, as example, apertures in the shroud **207** and apertures **209** formed in the light pipe **202**. Thus, the LEDs **206** can be cooled to a sufficient extent that the LEDs **206** in the aggregate can produce enough light to replicate, as an example, an incandescent bulb.

[0047] Still another example of an inside-out LED-based bulb **300** is shown in FIG. 8. In this example, LEDs **302** are positioned on a circuit board **304** atop heat dissipating structures **306** similar to as explained with respect to FIG. 4. However, in this example, a light pipe **308** includes a domed-portion **310** spanning a distal end **312** of the light pipe **308**. Additional LEDs can operationally be included to produce light that enters a proximal end of the light pipe as explained with respect to FIG. 1. The domed-portion **310** can act as a lens to distribute light produced by the LEDs **302** in a predetermined pattern, such as a pattern having the appearance of light produced by the distal end of a conventional incandescent bulb. Alternatively, the domed-portion **310** can act as

light pipe allowing some light to exit a distal end of the bulb **300** and guiding some light toward a proximal end of the light pipe **308**.

[0048] As shown in FIG. 9, another example of a base **12'** is shown in conjunction with the circuit board **16**, LEDs **18** and light pipe **20** from FIG. 1. In addition to including heat dissipating structures **22** spaced radially inward from the light pipe **20**, the base **12'** includes a flange **50** in thermal contact with the inner radial surface **40** of the light pipe **20**. Thermal paste **52** can be applied at a junction between the inner radial surface **40** and the flange **50** to facilitate heat transfer from the light pipe **20** to the flange **50**. Additionally, a reflector **54**, such as reflective paint or a mirrored insert, can be applied to the inner radial surface **40** to ensure that all or nearly all light exits the outer radial surface **38** or the distal end **20a** of the light pipe **20**. Additionally, the light pipe **20** can be modified in other manners to obtain a predetermined light distribution. For example, a layer of diffusive material can be applied over the outer radial surface **38** and/or the distal end **20a** of light pipe **20**, or the light pipe **20** can include surface roughening or other light diffracting structures along one or both of the surface **38** distal end **20a** of the light pipe **20**. Moreover, the treatment of the light pipe **20** can vary over its longitudinal dimension. For example, light diffracting structures can become more dense nearer the distal end **20a** of the light pipe **20**.

[0049] In addition to facilitating heat transfer via the inclusion of the heat transferring structures, other example of an inside-out LED-based bulb can have active heat dissipating devices. For example, FIGS. 10 and 11 show an example of an LED-based bulb **400** including a base **402**, an annular circuit board **404** having LEDs **406** mounted thereon, and an annular light pipe **408** that receives light produced by the LEDs **406** and defines a cavity **410** radially inward of the light pipe **408**. Heat dissipating structures **412**, such as pins, fins, or a lattice structure, can be disposed in the cavity **410**. Additionally, a piezo-driven fan **414** can be disposed in the cavity **410**. For example the heat dissipating structures **412** can define an open channel **413**, and the fan **414** can be disposed in the channel **413** and supported by adjacent heat dissipating structures **412**. The fan **414** can be operable in response its temperature becoming elevating to produce an airflow. Thus, the fan **414** can facilitate convective heat transfer from the heat dissipating structures **412** to an ambient environment about the bulb **400** without using any electricity. Alternatively, the piezo-driven fan **414** can be disposed at a different location, such as underlying the heat dissipating structures **412**.

[0050] The above-described examples have been described in order to allow easy understanding of the invention and do not limit the invention. On the contrary, the invention is intended to cover various modifications and equivalent arrangements, whose scope is to be accorded the broadest interpretation so as to encompass all such modifications and equivalent structure as is permitted under the law.

1. An LED based light comprising:
 - a base having a first end and a second end;
 - a light structure adjacent to the base and extending along a longitudinal axis of the light; wherein the light structure includes an inner surface and an outer surface and defines a cavity;
 - a heat dissipating structure extending into the cavity; and
 - at least one LED mounted in thermally conductive relation to the heat dissipating structure.

2. The LED based light of claim 1 further comprising a connector fixed to the first end of the base and configured to provide a physical connection to a conventional incandescent light fixture.

3. The LED based light of claim 2 further comprising electronics, wherein:

the base defines a compartment;

the electronics are disposed within the compartment;

the connector is further configured to provide an electrical connection to the conventional incandescent light fixture;

the electronics are in electrical communication with the connector and configured to receive a power from a conventional incandescent light fixture through the connector;

the electronics are in electrical communication with the at least one LED; and

the electronics are configured to supply a power suitable for transmission to the at least one LED.

4. The LED based light of claim 3 wherein the base includes a plurality of apertures configured to allow airflow between the compartment and an ambient environment external to the base.

5. The LED based light of claim 1 wherein:

the light structure is an annular flange;

the at least one LED includes at least one organic LED; and

the at least one organic LED is mounted to the outer surface and arranged to emit light in a predetermined light distribution.

6. The LED based light of claim 5 wherein the predetermined light distribution is the light distribution of a conventional incandescent bulb.

7. The LED based light of claim 1 wherein:

the light structure is a light pipe having a proximal end opposing a distal end;

the inner surface is configured for substantially total internal reflection of light; and

the light pipe is configured to distribute a light produced by the at least one LED in a predetermined light distribution.

8. The LED based light of claim 7 wherein the predetermined light distribution is the light distribution of a conventional incandescent bulb.

9. The LED based light of claim 7 wherein:

the heat dissipating structure extends from the base;

the base is made from a thermally conductive material; and

the at least one LED includes a first group of LEDs mounted in thermally conductive relation to the base.

10. The LED based light of claim 9 wherein:

the second end defines an annular platform;

an annular circuit board is mounted on the annular platform;

the first group of LEDs is mounted on and in electrical communication with the annular circuit board; and

the first group of LEDs is oriented to face substantially parallel to the longitudinal axis of the light.

11. The LED based light of claim 7 wherein:

the at least one LED includes a first LED disposed adjacent to the second end of the base;

the proximal end of the light pipe includes a proximal light receiving portion optically configured to receive a light produced by the first LED.

12. The LED based light of claim 11 wherein:

the light pipe is an annular light pipe;

the annular light pipe is solid between the inner surface and outer surface; and

the proximal light receiving portion defines an annular cutaway sized to receive the first LED.

13. The LED based light of claim 11 wherein:

the at least one LED includes a second LED oriented to face the inner surface; and

the inner surface includes an interior light receiving portion optically configured to receive a light produced by the second LED.

14. The LED based light of claim 1 wherein:

the heat dissipating structure is made from highly thermally conductive material; and

the heat dissipating structure has a high surface area to volume ratio.

15. The LED based light of claim 14 wherein the heat dissipating structure is at least one of a plurality of longitudinally extending pins or a plurality of longitudinally extending fins.

16. The LED based light of claim 1 further comprising an active heat dissipating device disposed within the cavity.

17. The LED based light of claim 1 further comprising a first thermal insulating shroud disposed about the base.

18. The LED based light of claim 1 further comprising a second thermal insulating shroud, wherein:

the second thermal insulating shroud extends over the distal end of the light structure to enclose the heat dissipating structure; and

at least one of the light structure or the second thermal insulating shroud includes a plurality of apertures configured to allow airflow between the cavity and an ambient environment external to the light structure.

19. A method making an LED based light comprising:

providing a base having a first end and a second end;

mounting a light structure having an inner surface and an outer surface and defining a cavity adjacent to the base so that the light structure extends along a longitudinal axis of the light;

providing a heat dissipating structure within the cavity; and

mounting at least one LED in thermally conductive relation to the heat dissipating structure.

20. The method of claim 19 wherein the light structure is an annular flange, further comprising:

mounting the annular flange in thermally conductive relation to the heat dissipating structure; and

mounting the at least one LED to the outer surface.

21. The method of claim 19 wherein:

the light structure is a light pipe having a proximal end opposing a distal end;

the inner surface is configured for substantially total internal reflection of light; and

the light pipe is configured to distribute a light produced by the at least one LED in a predetermined light distribution.

22. An LED based light for replacing a conventional incandescent light bulb comprising:

a connector configured to provide a physical connection to a conventional incandescent light fixture;

at least one LED;

a light pipe having an inner surface and an outer surface and extending along a longitudinal axis of the light to define a cavity radially inward of the inner surface; wherein the

light pipe is optically configured to receive a light emitted by the at least one LED and distribute substantially all of the received light radially outward from the light pipe in a predetermined light distribution; and
a heat dissipating structure in thermally conductive relation to the at least one LED and extending into the cavity.

23. The LED base light of claim **22** wherein the outer surface is linear and extends radially outward along the longitudinal axis of the light to form a conical shape.

24. The LED base light of claim **23** wherein the outer surface is contoured to form a bulbous profile.

* * * * *